



# Assessment of Sampling Error Associated with Collection and Analysis of Soil Samples at a Firing Range Contaminated with HMX

Thomas F. Jenkins, Marianne E. Walsh, Philip G. Thorne,  
Sonia Thiboutot, Guy Ampleman, Thomas A. Ranney,  
and Clarence L. Grant

September 1997

**Abstract:** Short-range and mid-range (grid size) spatial heterogeneity in explosives concentrations within surface soils was studied at an active antitank firing range at the Canadian Force Base-Valcartier, Val-Bélair, Quebec. The range has been in use for over 20 years. Intensive sampling was conducted over short distances using a 6-m square grid (36-m<sup>2</sup>) pattern including two target tanks. Sixteen grids were installed. Four area-integrated surface samples were formed into piles, one in each quadrant of each grid, using a circular pattern that included about 10% of the top 5 cm of the quadrant. After in-situ homogenization of a pile, several random aliquots were combined to form a representative sample. Replicates were collected to assess the representativeness achieved. In addition, grid composites were prepared by combining equal portions of the

four subgrid samples for each of sixteen grids. In nine of the subgrids, a second area integrated sample was prepared. On-site analysis showed concentrations of HMX ranging from as high as 1640 mg/kg near one target to 2.1 mg/kg at a distance of 15 m from the target. On the other hand, TNT concentrations were much lower than would be expected based on the 70:30 composition ratio of HMX to TNT in the melt-cast explosive used on site. A colorimetric method, originally developed to analyze for RDX, was found to provide concentration estimates for HMX that were in excellent agreement with laboratory results. Spatial heterogeneity of HMX concentrations was large on both short- and mid-range scales and this factor dominated the overall uncertainty associated with site characterization. Relatively minor uncertainties were due to analytical error.

**How to get copies of CRREL technical publications:**

Department of Defense personnel and contractors may order reports through the Defense Technical Information Center:

DTIC-BR SUITE 0944  
8725 JOHN J KINGMAN RD  
FT BELVOIR VA 22060-6218  
Telephone 1 800 225 3842  
E-mail help@dtic.mil  
msorders@dtic.mil  
WWW http://www.dtic.dla.mil/

All others may order reports through the National Technical Information Service:

NTIS  
5285 PORT ROYAL RD  
SPRINGFIELD VA 22161  
Telephone 1 703 487 4650  
1 703 487 4639 (TDD for the hearing-impaired)  
E-mail orders@ntis.fedworld.gov  
WWW http://www.fedworld.gov/ntis/ntishome.html

A complete list of all CRREL technical publications is available from

USACRREL (CECRL-LP)  
72 LYME RD  
HANOVER NH 03755-1290  
Telephone 1 603 646 4338  
E-mail techpubs@crrel.usace.army.mil

**For information on all aspects of the Cold Regions Research and Engineering Laboratory, visit our World Wide Web site:**  
<http://www.crrel.usace.army.mil>

Special Report 97-22

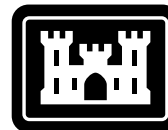

**US Army Corps  
of Engineers®**  
Cold Regions Research &  
Engineering Laboratory

# Assessment of Sampling Error Associated with Collection and Analysis of Soil Samples at a Firing Range Contaminated with HMX

Thomas F. Jenkins, Marianne E. Walsh, Philip G. Thorne,  
Sonia Thiboutot, Guy Ampleman, Thomas A. Ranney,  
and Clarence L. Grant

September 1997

Prepared for  
U.S. ARMY ENVIRONMENT CENTER  
and  
DEPARTMENT OF NATIONAL DEFENCE, CANADA

Approved for public release: distribution is unlimited.

## **PREFACE**

This report was prepared by Dr. Thomas F. Jenkins, Research Chemist, Marianne E. Walsh, Chemical Engineer, and Philip G. Thorne, Research Physical Scientist, Geological Sciences Division, Research and Engineering Directorate, U.S. Army Cold Regions Research and Engineering Laboratory (CRREL), Hanover, New Hampshire, Dr. Sonia Thiboutot and Dr. Guy Ampleman, Defence Research Establishment-Valcartier (DREV), Val-Bélair, Quebec, Thomas A. Ranney, Science and Technology Corporation, Hanover, New Hampshire, and Dr. Clarence L. Grant, Professor Emeritus, Chemistry Department, University of New Hampshire, Durham, New Hampshire. Funding for participants from the United States was provided by the U.S. Army Environmental Center, Aberdeen Proving Ground, Maryland, Martin H. Stutz, Project Monitor. The Canadian portion of this study was supported by funds from the Directorate of Ammunition Programme Management, Engineering Services, Department of National Defence, Canada.

The authors gratefully acknowledge Harry Craig (EPA Region 10), Charles Collins (CRREL), Martin H. Stutz (AEC), and Dr. C.M. Reynolds (CRREL) for their technical review of this manuscript. In addition, the authors acknowledge Jane Mason, CRREL, for assistance in preparation of this report.

This publication reflects the personal views of the authors and does not suggest or reflect the policy, practices, programs or doctrine of the U.S. Army or Government of the United States. The contents of this report are not to be used for advertising or promotional purposes. Citation of brand names does not constitute an official endorsement or approval of the use of such commercial products.

## CONTENTS

	Page
Preface .....	ii
Introduction.....	1
Background .....	1
Objectives .....	2
Experimental .....	3
Sampling site description and sample collection .....	3
Sample storage and processing .....	5
On-site sample extraction and filtration .....	6
On-site analytical methods .....	6
Laboratory analysis of acetone extracts .....	8
Laboratory analysis using Method 8330 .....	8
Water samples .....	8
Chemicals and reagents .....	9
Statistical analyses .....	9
Results and discussion .....	9
Depth of contamination .....	9
Short-range heterogeneity .....	11
Results for characterization of grid-sized areas for HMX .....	13
Comparison of HMX concentration estimates from on-site colorimetric and laboratory methods for subgrid and grid-composite samples .....	18
Concentration estimates for TNT in subgrid and grid-composite samples .....	19
Co-contaminants .....	22
Water analysis .....	23
Analysis of explosives residues remaining on metallic debris .....	24
GC comparisons .....	24
Summary and conclusions .....	24
On-site methods .....	24
Short-range spatial heterogeneity .....	24
Midscale spatial heterogeneity .....	25
Accumulation of explosives residues at an active antitank firing range ...	25
Concluding remarks .....	25
Literature cited .....	27
Appendix A: Individual analyses for surface soil samples obtained in each subgrid and for grid composites .....	29
Abstract .....	53

## ILLUSTRATIONS

### Figure

1. Chemical structure of HMX .....	2
2. Canadian Force Base-Valcartier firing range study site .....	2
3. Diagram of 66-mm M72 rocket fired at CFB-Valcartier .....	3
4. Sampling area at CFB-Valcartier firing range site, showing HMX concentrations from on-site measurements .....	3
5. Sampling scheme for short-range heterogeneity study .....	4
6. Sampling path for obtaining “area integrated” samples .....	5
7. Subgrid sampling path and sample collection .....	5
8. HPLC chromatograms for a standard and two acetone soil extracts showing analytical difficulty in quantifying TNT when large concentration of 2,4-DNT was present .....	8
9. GC-ECD chromatograms for a standard and two acetone soil extracts .....	9
10. HMX concentrations from commercial laboratory analysis using Method 8330 .....	14
11. Dependence of RSDs of duplicate subgrid samples on mean HMX concentration .....	16
12. Correlation analysis of HMX concentration estimates from the colorimetric on-site method with those from HPLC analysis of the same acetone extracts .....	18
13. Correlation analysis of HMX concentration estimates from the colorimetric on-site method with those from EPA Method 8330 using separate subsamples .....	18
14. Sampling area at CFB-Valcartier firing range site, showing TNT concentrations from on-site colorimetric analyses .....	19
15. Correlation analysis of TNT concentration estimates from the colorimetric on-site method with those from HPLC analysis of the same acetone extracts .....	22
16. Correlation analysis of TNT concentration estimates from the EIA on-site method with those from HPLC analysis of the same acetone extracts .....	23

## TABLES

### Table

1. Analytical results from initial samples used to assess depth of contamination .....	10
2. Results from short-range spatial heterogeneity study for HMX with soil samples from subgrid D2B .....	11
3. Statistical analysis of HMX results from discrete and composite samples taken from subgrid D2B for short-range spatial heterogeneity assessment .....	12
4. Comparison of HMX concentration estimates using the on-site colorimetric results for individual subgrids, mean of four subgrids, and grid composites .....	15

Table	Page
5. Comparison of measures of analytical precision, accuracy and discrete sample representativeness for CFB-Valcartier results relative to those found for other explosives analytes at Monite, Hawthorne, and Volunteer .....	15
6. HMX concentrations from on-site colorimetric analysis for subgrids subjected to repeat sampling .....	16
7. HMX concentrations from on-site colorimetric method for duplicate subgrid subsamples .....	17
8. Comparison of concentration estimates for TNT from various on-site and laboratory methods .....	20
9. Apparent false positives and false negatives relative to Method 8330 results for TNT .....	21
10. Concentrations of HMX, RDX, and TNT detected in groundwater and surface water samples at CFB-Valcartier .....	23
11. Fractionation of total error into analytical and sampling components .....	26

# Assessment of Sampling Error Associated with Collection and Analysis of Soil Samples at a Firing Range Contaminated with HMX

THOMAS F. JENKINS, MARIANNE E. WALSH,  
PHILIP G. THORNE, SONIA THIBOUTOT, GUY AMPLEMAN,  
THOMAS A. RANNEY, AND CLARENCE L. GRANT

## INTRODUCTION

### Background

Recently, we reported large short-range spatial heterogeneity of explosives contaminant concentrations in surface soils at explosives-contaminated sites (Jenkins et al. 1996). Nine locations were sampled at three installations; the sampling locations varied in the principal contaminant present, mode of contamination, and soil type. Seven discrete samples were collected at each sampling location from a 1.22-m circle. The samples were analyzed on-site using colorimetric methods (Jenkins and Walsh 1992), and in the laboratory using SW846 Method 8330, the standard reversed-phase high performance liquid chromatography (RP-HPLC) method for the determination of nitroaromatics and nitramines in soil (EPA 1995). The results indicated that regardless of whether the major contaminant was 2,4,6-trinitrotoluene (TNT), 2,4-dinitrotoluene (DNT) or ammonium picrate (AP), or whether on-site or laboratory results were used, extreme heterogeneity in contaminant concentrations was found among the seven samples at each location. Ratios of the highest concentration obtained among the seven discrete samples divided by the lowest of the seven ranged from about 3 to greater than 600, with a mean value of about 73 (median value was 50).

These results have implications for developing sampling designs to characterize explosives-contaminated sites, if data are expected to represent average site conditions. For example, the TNT concentration at one location varied from about 40,000 mg/kg for one discrete sample to only

about 150 mg/kg for a second discrete sample collected only 61 cm distant. Either of these were legitimate discrete samples that could be used to represent this grid location, according to typical sampling plans now being used at explosives-contaminated installations. Very different decisions relative to the need for site remediation might be made, though, depending on which of these results happened to be the sample collected to represent the grid location.

A positive result from this work, however, was the demonstrated ability to prepare composite samples on site that were a good physical average of the mathematical mean of the discrete samples making up the composite (Jenkins et al. 1996). The use of composite sampling with on-site analysis provides an attractive alternative to the conventional use of discrete sampling strategies and analysis at off-site laboratories.

While a fairly large body of information is available relative to explosives concentrations at sites impacted by manufacturing operations (Walsh et al. 1993), very little information is available on the levels of accumulation of explosives residues at active firing ranges. In addition, we have been unable to locate reports of site characterization where HMX (octahydro-1,3,5,7-tetranitro-1,3,5,7-tetrazocine) (Fig. 1) was the principal contaminant. We recently reported that a colorimetric on-site method for RDX (hexahydro-1,3,5-trinitro-1,3,5-triazine) would detect HMX (Jenkins et al. 1995), but no on-site evaluation of this method for quantitative estimation of HMX has been reported.

The firing range characterized in this study is a Canadian antitank firing range, which had been



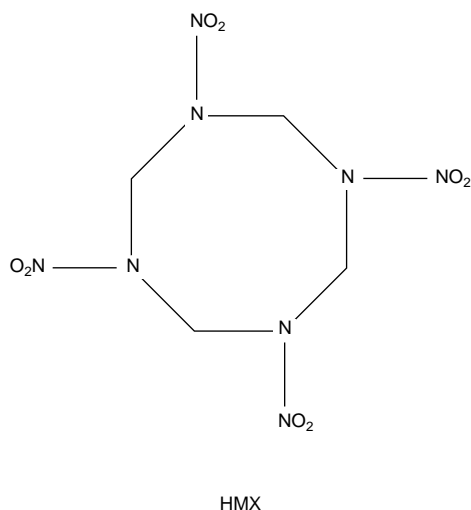

Figure 1. Chemical structure of HMX.

previously sampled and found to be contaminated with energetic compounds, HMX being the major contaminant. This initial characterization was conducted within the framework of a Canadian program on the characterization of sites potentially contaminated with energetic materials (Thiboutot et al. in press). The objective of the Canadian program has been the assessment of the level of contamination by energetic compounds in various type of sites such as firing ranges, open burning/open detonation ranges, demolition ranges and production sites. In addition to site characterization, this program includes the development of bioremediation technologies capable of remediating explosives contaminated sites.

The first soil sampling of the antitank range was conducted in May 1995. Four surface composite samples were taken at a distance between 1 and 3 m from each side of four target tanks. Each surface composite was prepared from 10 discrete samples. Analysis of these initial samples revealed that HMX was the major contaminant on site, with lesser amounts of RDX and TNT. A second sampling was conducted in October 1995 and was concentrated near tank D (Fig. 2). Seven locations were sampled at three different depths. Analysis of these samples revealed that greater than 90% of the contamination was concentrated in the top 15 cm of soil. Detailed results of both sampling campaigns are reported elsewhere (Thiboutot et al. in press).

### Objectives

The principal objective of the work described here was to develop an innovative strategy for characterizing explosives contaminated sites that 1) takes advantage of the ability to generate near real time information from on-site analyses, and 2) overcomes the problem of large localized spatial heterogeneity in contaminant concentrations. A colorimetric method, initially developed for RDX, was evaluated for estimating HMX soil concentrations, and two commercially available on-site methods were compared for rapid determination of TNT. To overcome problems due to spatial heterogeneity, a simple compositing approach was evaluated for obtaining representative samples within defined geographic boundaries. Finally, this study documented the levels



Figure 2. Canadian Force Base-Valcartier firing range study site.

of accumulation of HMX and TNT on an active firing range, where the munition fired was a melt-cast explosive composed of a 70:30 mixture of HMX and TNT.

## EXPERIMENTAL

### Sampling site description and sample collection

This study was conducted in September 1996 at an antitank range at the CFB-Valcartier, Quebec, near Quebec City (Fig. 2). This is an active firing range where rockets filled with 0.3 kg (0.66 lb) of the melt-cast explosive octol (70% HMX:30% TNT) have been fired on a routine basis for over 20 years (Fig 3). Firing at the antitank range had occurred the week prior to this field sampling study, and the ground surface was littered with shell fragments, pieces of plastic and ceramic, springs, fins, and other debris. Some of the rockets were unexploded, but sheared open to expose the explosive composition octol. Analy-

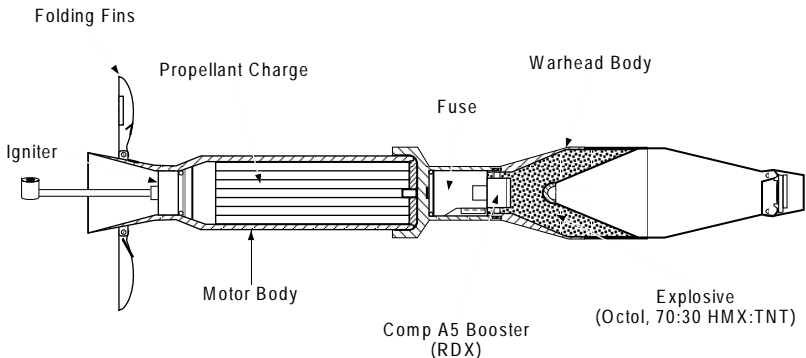

Figure 3. Diagram of 66-mm M72 rocket fired at CFB-Valcartier.

sis of a chunk of the explosive composition using HPLC and NMR (nuclear magnetic resonance) spectroscopy confirmed the 70:30 ratio of HMX and TNT.

The firing range is about 100 ha in size and has four target tanks, two in a fairly level region of the site (labeled tanks C and D) near the access road. Sampling studies were conducted in an area encompassing these two target tanks as shown in Figure 4. The sandy, well-drained soil in front of

### DREV HMX

- $\bar{X}$  Mean of all samples in grid, less duplicates
- Location of sample
- Location of duplicate (*d*)

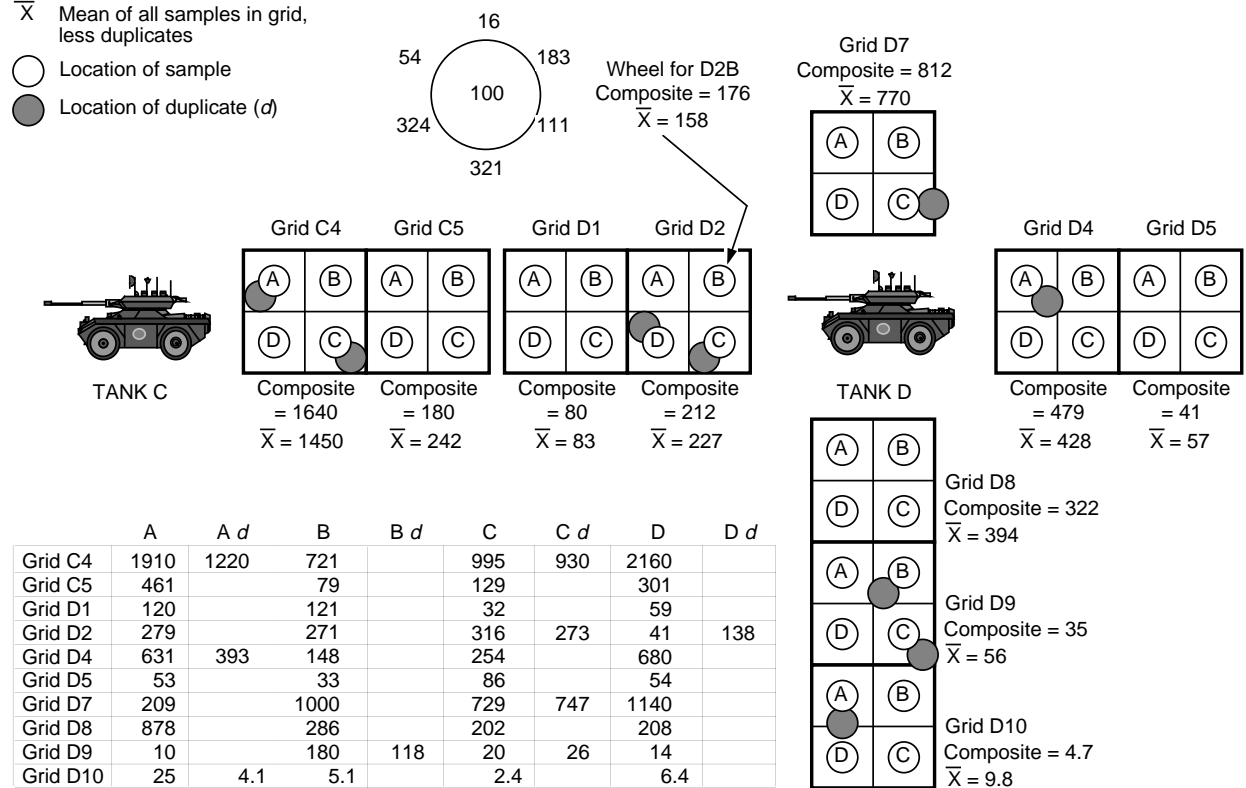

Figure 4. Sampling area at CFB-Valcartier firing range site, showing HMX concentrations from on-site measurements.

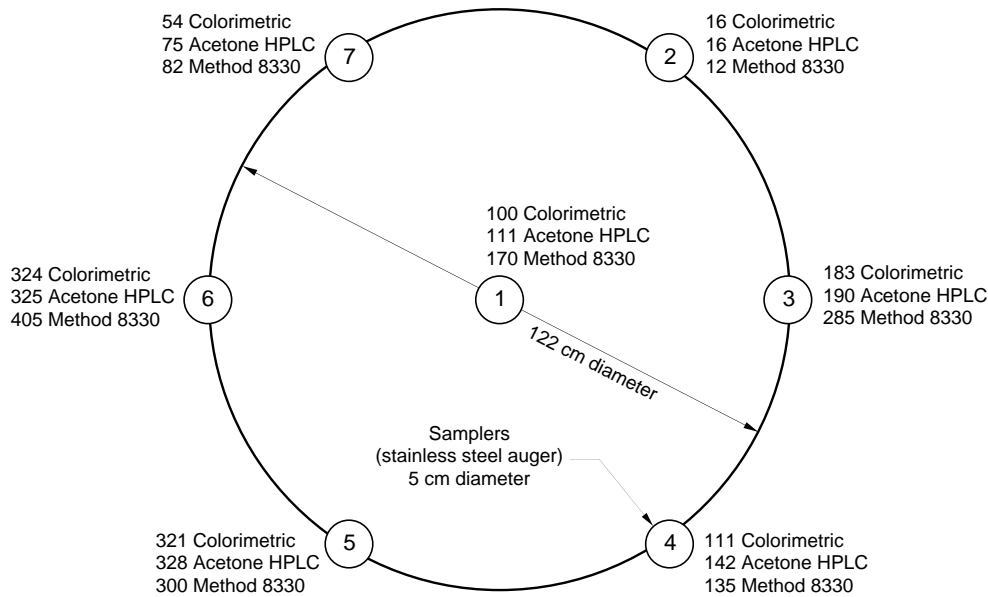

Figure 5. Sampling scheme for short-range heterogeneity study (HMX concentrations are shown from subgrid D2B). Numbers 1–7 are discrete samples collected in a localized area. Values are in milligrams/kilogram.

and between these two tanks was unvegetated. Behind tank D, the soil was moist and moss covered. In the initial stage of the investigation, preliminary soil samples were collected in two areas to assess the near-surface concentration gradient of HMX and TNT with soil depth. This sampling was done using a 2.5-cm soil corer, and samples were collected over two depth regions: 0 to 7.5 cm and 7.5 to 15 cm. Colocated surface samples (0–2.5 cm) were also collected for comparison. Cores were divided in the field and returned to the sample processing area in plastic bags.

The second set of soil samples was collected near tank D (in an area subsequently labeled subgrid D2B) to provide an estimate of short-range heterogeneity in HMX and TNT concentrations that could be compared with results obtained for other explosives-contaminated sites (Jenkins et al. 1996). For this portion of the work, a plastic template was placed on the ground with the center at the selected sampling location, and seven samples were collected in a wheel pattern, with sample number 1 in the center (Fig. 5). The radius of the wheel was 61 cm and samples arranged around the wheel were separated by 61 cm. All seven soil samples were collected from 0 to 15 cm using a manual 5.6-cm-diam. stainless-steel hand auger. Vegetation when present was removed. Cores were transferred to plastic Ziploc bags and taken to a processing area. The auger

was carefully cleaned with a brush prior to its next use.

Based on the results of the on-site analyses from the first two sets of samples, we divided the area around tanks C and D into ten 6- $\times$ -6-m grids (labeled D1 through D10, and C4 and C5) and subdivided each grid into four 3- $\times$ -3-m subgrids as shown in Figure 4. Subsequently the Canadian researchers alone added grids C6 through C10 and D11. These samples were analyzed only by Method 8330. The following procedural details applies only to the characterization of the first 10 grids. Samples within each subgrid were obtained as follows. A spading shovel was used to scrape the top 5 cm of soil from a 20-cm wide circular path of radius 77 cm located in the center of each subgrid; this path sampled about 10% of the surface within the subgrid (Fig. 6). The soil scraped from the surface was piled in the center of the circle and mixed thoroughly with the spading shovel and a small hand shovel (Fig. 7). Pieces of metallic and ceramic debris from munition detonation were removed by hand and a subsample of about 1 kg of soil was collected from random locations in the pile. Duplicate portions of soil from these soil piles were collected in nine randomly selected subgrids from a total of 40 to assess the degree of uncertainty due to subsampling the piles. Samples prepared in this manner were designated *area integrated*. In these same nine

subgrids, duplicate area integrated samples were prepared in a manner identical to that described above, except that the sampled area was offset from the initial one as shown for each of the selected subgrids in Figure 4. This was done to assess

the uncertainty due to the fact that only about 10% of a subgrid was included in any one area integrated sample. All samples were returned to the processing area in plastic Ziploc bags in a cooler.

#### Sample storage and processing

Soil samples were kept cold and in the dark until processed. Processing was conducted either the same day soils were collected or the morning following collection the previous afternoon. Soil samples varied somewhat in moisture content and texture from location to location. Some soils were quite dry and consisted mainly of sands and gravels, while others had a much greater level of moisture and had a much greater organic content.

Individual soil samples in Ziploc bags were shaken and kneaded and then emptied into aluminum pans. Soils were further homogenized by breaking up clumps with gloved hands and stirring. Small stones and any other debris were removed, samples were coned and quartered, and 20-g subsamples were weighed into 125-mL plastic wide-mouth bottles for extraction with acetone. For the wheel samples, used to assess short-range heterogeneity, samples were processed in an identical manner to that described elsewhere (Jenkins et al. 1996) and duplicate subsamples

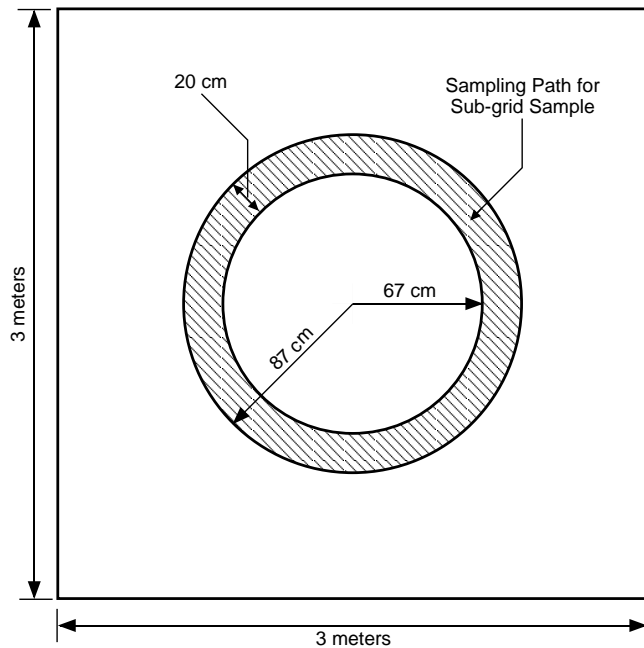

Figure 6. Sampling path for obtaining "area-integrated" samples.



Figure 7. Subgrid sampling path and sample collection.

were collected for on-site analysis and for subsequent laboratory analysis using Method 8330. In all cases separate subsamples were used for moisture content determination, and analysis results were corrected to a dry weight basis.

Weighed portions from each of the four area-integrated subgrid samples from within a grid were combined and homogenized to prepare a composite sample to represent each grid. Duplicate 20-g portions were collected for on-site analysis of each composite grid sample, and also for area integrated subgrid samples for subgrids D2 and D5. We used the results from these duplicates to compute analytical uncertainty, i.e., the uncertainty associated with subsampling, extraction and analysis.

### On-site sample extraction and filtration

Each 20-g soil subsample was extracted with 100 mL of acetone. Based on a short extraction kinetic study with the initial samples collected, a 30-minute extraction on a vortex mixer was needed, rather than the 3-minute period specified by the manufacturers of the on-site tests. The extracts were allowed to settle for at least 30 minutes and a 50-mL aliquot was removed from the extraction bottle with a disposable Plastipak syringe and filtered through a Millex SR filter membrane. All samples collected by the joint Canadian-United States team were analyzed using the TNT and RDX methods by EnSys Corporation (now Strategic Diagnostics, Inc.). Some of the soil extracts were also analyzed using the D TECH enzyme immunoassay TNT and RDX methods (EM Science). The acetone extracts were subsequently returned to CRREL and analyzed using RP-HPLC separations similar to those described in SW846 Method 8330 (EPA 1995).

### On-site analytical methods

#### Colorimetric HMX method

The colorimetric method used to estimate HMX at CFB-Valcartier was originally developed for RDX (Walsh and Jenkins 1991) and is now commercially available through EnSys as their RDX field method. When RDX is either not present, or present at a much lower concentration than HMX, this method can be used to estimate HMX concentrations (Jenkins et al. 1995). The method is based on the Franchimont and Griess reactions as shown in eq 1:

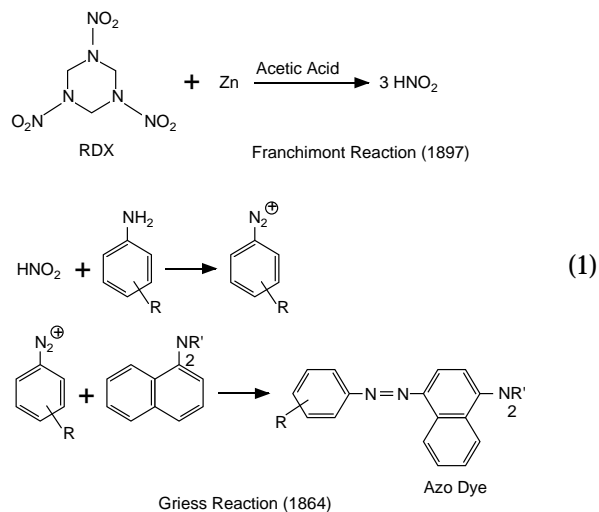

Extracts were analyzed as described elsewhere (Walsh and Jenkins 1991) except that the extracts were not passed through an anion exchanger prior to further processing. The use of the anion exchanger is required to remove interferences from nitrate and nitrite ions, often present in areas where soils have been given chemical fertilization. Since the history of this site was known and fertilization had not been used, the anion exchange step was eliminated.

A 5.0-mL aliquot of each acetone extract was mixed with 0.5 mL of glacial acetic acid and poured into the barrel of a 10-mL syringe loaded with 0.3 g of zinc dust and equipped with a Millex SR-filter unit. The plunger was fitted to the barrel of the syringe and after 15 seconds of contact with the zinc, the solution was filtered into a vial containing 20 mL of deionized water and the contents of a Hach NitriVer 3 powder pillow. The vial was shaken to mix and allowed to stand for a minimum of 15 minutes.

The development of a pink color is indicative of the presence of either a nitramine such as RDX or HMX, or an organonitrate ester such as nitroglycerine (NG), nitrocellulose (NC) or pentaerythritol tetranitrate (PETN). At the tank firing range at CFB-Valcartier, the only munition fired is an antitank device containing HMX and TNT, and so the development of a pink color here indicates the presence of HMX. Concentrations of HMX were estimated by measuring the absorbance at 507 nm using a Hach DR/2000, a battery-operated spectrophotometer. If absorbance values were above 1.0, extracts were diluted with acetone (3% water added) and re-analyzed.

### Colorimetric TNT method

The colorimetric on-site method used for TNT analysis of acetone soil extracts is commercially available from EnSys. This is a commercialized version of the method developed by Jenkins (1990) and utilizes the Janowsky reaction (eq 2). If TNT is present in the acetone extracts, reaction with 1 drop of the EnSys color reagent produces a pink to red color indicative of the presence of the Janowsky anion of TNT:

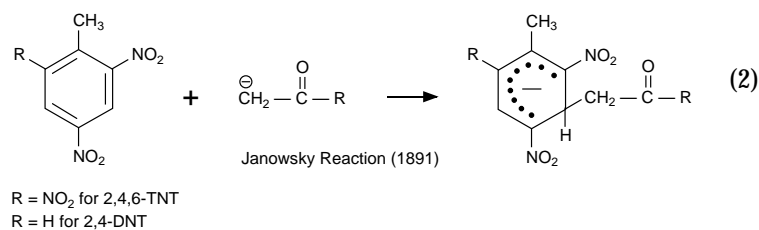

A 25-mL aliquot of the acetone soil extract is added to a 25-mL glass cuvette and the initial absorbance measured with a Hach DR/2000 spectrophotometer at 540 nm. A drop of the EnSys color reagent is then added to the cuvette and mixed by swirling. The solution is allowed to stand for one minute and then the absorbance is again measured at 540 nm. Extracts were diluted as appropriate, such that absorbances after reaction with the EnSys reagent were less than 1.0. The concentration of TNT is estimated by subtracting twice the initial absorbance from the final absorbance and dividing by the response factor obtained from a TNT standard with a solution concentration of about 4 mg/L. Doubling the initial absorbance prior to subtraction takes into account the increased absorbance caused by reaction of humic organics in the extract with base, as discussed elsewhere (Jenkins and Walsh 1992).

### D TECH immunoassay for RDX and TNT

The D TECH enzyme immunoassay (EIA) method used for both RDX and TNT is commercially available from EM Science (Teany and Hudak 1994, Teany et al. 1995). The components of this EIA include RDX- and TNT- specific antibodies covalently linked to small latex particles, which are collected on the membrane of the cup assembly. A color-developing solution added to the surface of the cup assembly reveals a color inversely proportional to the concentration of RDX or TNT equivalent in the sample. RDX and TNT

are measured as parts-per-million (mg/kg) in soil samples, in effective ranges between 0.5 and 5 ppm for TNT and between 0.5 and 6 ppm for RDX. In the case where results higher than 5 ppm were obtained for TNT ("Hi" reading), dilution of the extracts were made by factors of two to four in order to obtain a result within the effective range of the test.

Soils were extracted with acetone as described above and analyzed according to the instructions provided with the D TECH TNT and RDX explosives test kits. The same acetone extracts used for the colorimetric on-site methods were used for EIA methods as well. A 1.0-mL aliquot of clear acetone extract was transferred into a bottle of buffer solution (bottle 2 in the extraction pack). The prescribed volumes of the soil extracts were added to the vials containing enzyme-labeled

RDX or TNT and antibody-coated latex particles. Those mixtures were allowed to stand for 2 minutes for the TNT test and 5 minutes for the RDX test to allow the explosive molecules to interact with the antibody binding sites. Negative control references were processed with each analysis. Samples and references received identical treatments and both solutions were poured onto the respective sides (test or reference) of the porous membrane cup assembly. The conjugate solutions were allowed to pass through the membranes, and the membranes were washed and treated with a color-developing solution. The reference sides of the cup were used to determine the end-point of the color development. The time for complete color development was less than 10 and 15 minutes for TNT and RDX, respectively. All of these manipulations and readings were done at room temperature. RDX EIA tests were performed only on the first set of samples, since it was clear that HMX was the main contaminant, and cross-reactivity with RDX EIA test was not sufficient to serve as a HMX evaluation tool. All samples were tested with the TNT EIA method.

Results from the test kits were determined with the DTECHTOR environmental field test meter (EM Science). This device is a hand-held reflectometer powered with a 9-V plug-in battery. It measures the amount of light reflected from the surfaces of the color-developed test and reference sides of the cup assembly. Readings are in percentages, which can then be translated into TNT or RDX equivalent concentration ranges.

## Laboratory analysis of acetone extracts

### RP-HPLC

The RP-HPLC conditions were modified from those in EPA Method 8330 (EPA 1995) to accommodate the change in extraction solvent from acetonitrile to acetone, which absorbs in the UV and can interfere with HMX and RDX determination. For each sample, 1.00 mL of the acetone extract was mixed with 5.00 mL of reagent grade water prior to analysis using an LC-CN column (Supelco) eluted with 1:1 methanol:water at 1.2 mL/min. Absorbance was recorded at 254 nm on a Spectra Physics Model 8490 variable wavelength detector and peaks were recorded on a Hewlett-Packard 3396 Digital Integrator operated in the peak height mode.

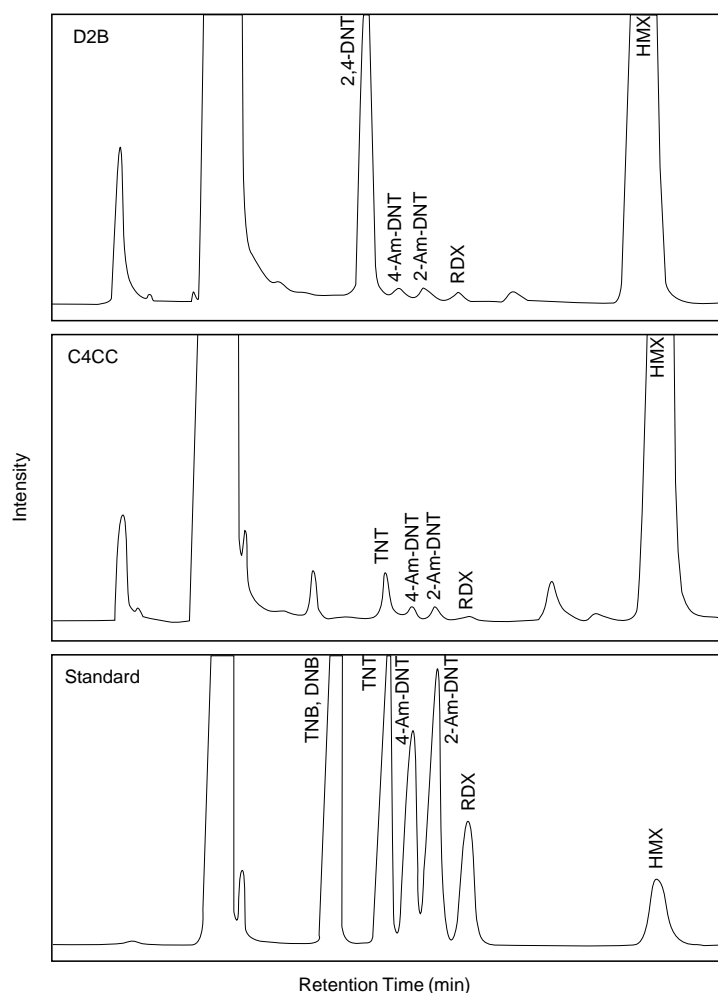

Figure 8. HPLC chromatograms (LC-CN) for a standard and two acetone soil extracts showing analytical difficulty in quantifying TNT when large concentration of 2,4-DNT was present.

The elution order for LC-CN is opposite that of LC-18, and hence acetone did not interfere with HMX on LC-CN. Results from the LC-CN analysis for some of the acetone extracts showed the potential presence of high concentrations of 2,4-DNT, which, due to the close elution times of 2,4-DNT and TNT, prevented TNT determination (Fig. 8). The compounds present in these extracts and in some others that appeared to contain HMX, and the amino-DNT transformation products of TNT, were confirmed by GC-ECD (gas chromatography—electron capture detection) as described below.

### GC/ECD analysis

A 1.0- $\mu$ L aliquot of the acetone extract was directly injected (270°C) into an Hewlett-Packard 5890 gas chromatograph equipped with an electron capture detector (300°C). The temperature of the dimethylpolysiloxane fused silica column (J&W DB-1, 0.53 mm ID, 6 m, 1.5- $\mu$ m film thickness) was held at 100°C for 2 min, then ramped at 10°C/min to 200°C, and 20°C/min to 250°C and held for 3 min. The carrier gas was hydrogen (LV [linear velocity] = 150 cm/s). Examples of the GC-ECD chromatograms obtained for a standard and the same acetone soil extracts depicted in Figure 8 are presented in Figure 9.

### Laboratory analysis using Method 8330

Subsamples of all the soil samples collected for this study were sent to an independent commercial laboratory for analysis. Duplicate 2-g portions of soil were analyzed using acetonitrile extraction and reversed-phase HPLC as described in EPA Method 8330 (EPA 1995).

### Water samples

Groundwater was collected from a monitoring well located between the firing point and the target tanks. Surface water was collected from two impact craters near tanks A and B (located in the upper reaches of the site). These water samples were analyzed at DREV within one day of collection using Method 8330 by the salting-out solvent extraction protocol. Subsamples were refrigerated and analyzed at CRREL three weeks later using HPLC and GC-ECD methods.

## Chemicals and reagents

All standards for HMX, TNT and the other explosives analytes were prepared from Standard Analytical Reference Materials (SARMS) obtained from the U.S. Army Environmental Center, Aberdeen Proving Ground, Maryland. Standards of HMX and TNT in acetone were prepared using OmniSolv grade acetone from EM Science.

All acetone used for soil extraction and glassware cleaning was reagent grade obtained from Anachemia. Methanol used in the laboratory for preparation of HPLC eluents was either Caledon or Sigma-Aldrich HPLC grade. Deionized water from the DREV central system was used in the field for cleaning, and for addition to extracts to ensure that an adequate water content was present for the color-forming reaction. Laboratory grade water used for preparation of HPLC eluents at CRREL was obtained from a Millipore Milli-Q Type 1 reagent grade water system.

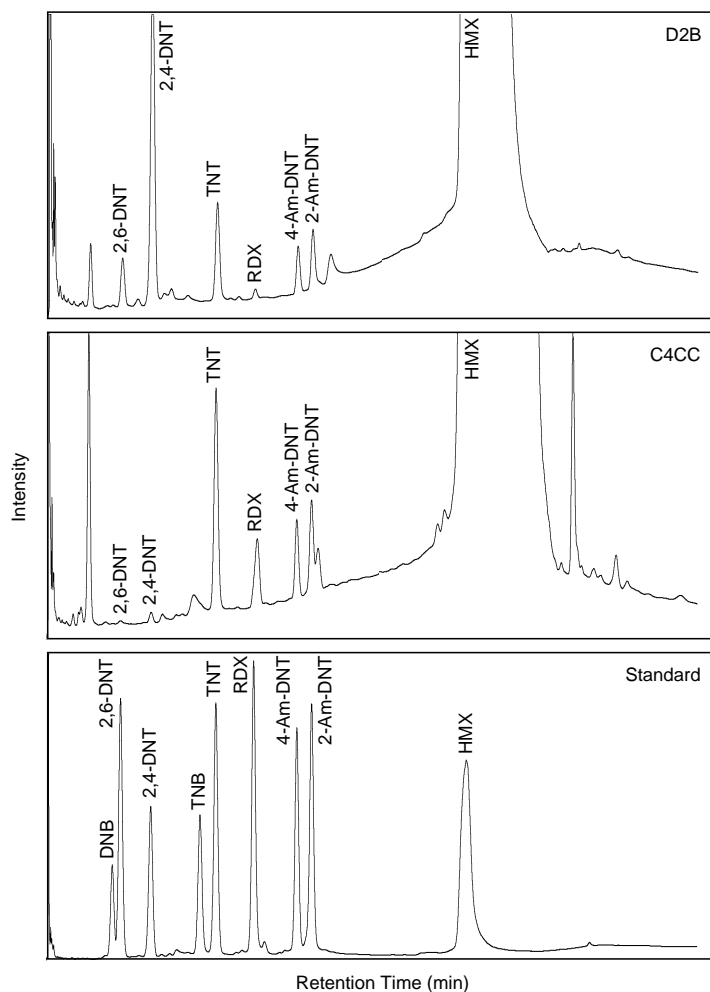

Figure 9. GC-ECD chromatograms for a standard and two acetone soil extracts.

## Statistical analyses

To detect significant concentration differences among the seven sample positions for the short-range heterogeneity study (wheel samples from D2B), we subjected analytical results for HMX from the on-site colorimetric method, from the acetone HPLC method, and from Method 8330 to one variable of classification, completely randomized analysis of variance (ANOVA) using Microsoft Excel 5.0. Since the ANOVA demonstrated significant differences among sample positions for this sampling location, least significant differences (LSDs) were computed to identify specific differences. Variances were fractionated to yield estimates of the standard deviations for subsampling plus analysis ( $S_A$ ) and for sampling error ( $S_C$ ). All references to analytical error for this portion of the study should be understood to include contributions from mixing and subsampling, extraction, dilution, measurement and concentration computations, while sampling error refers to spatial heterogeneity at the sampling location. We also computed means and standard deviations of duplicates, overall means of the seven duplicates, plus means and standard deviations of composites. Analytical precision of the seven duplicates for each sampling location and each analysis method was expressed as the average of the seven RSDs (relative standard deviations).

Correlations based on the linear least squares model with intercept were made between the HMX results from the on-site colorimetric method and both the Method 8330 results and those from acetone HPLC analysis. Computations were conducted separately for the results from the short-range heterogeneity study and for the data from subgrid and grid-composite samples. Intercepts were tested to determine whether they were significantly different from zero at the 95% confidence level. When appropriate, zero intercept models were fitted.

## RESULTS AND DISCUSSION

### Depth of contamination

In the initial stages of this work we collected three 0–15-cm cores plus three collocated 0–2.5-cm surface samples at each of two locations near target tank D.



These locations were subsequently labeled grids D2 and D5. Cores were divided into two depth intervals (0 to 7.5 cm and 7.5 to 15 cm). The two core segments were each analyzed in duplicate, while only a single analysis was conducted for the surface samples.

The EIA RDX test was run on this first set of samples to evaluate if it could be used to assess HMX contamination. There is a cross-reactivity response for HMX in the RDX explosive test kit, as described by the D TECH documentation. It was our goal to examine if this cross-reactivity

could be exploited to estimate the concentration of HMX when present at high concentration in soil samples. Results of the respective concentrations of RDX determined by both EIA and HPLC for the acetone extracts are reported in Table 1. RDX was detected in only seven samples out of 30 samples analyzed by HPLC. However, a positive response was obtained for two-thirds of the samples with the EIA D TECH test. This confirms the low cross-reactivity toward HMX for the RDX EIA test, leading to a high rate of false positives for RDX determination in the presence of high

**Table 1. Analytical results from initial samples used to assess depth of contamination.**

Grid location	Depth (cm)	HMX (mg/kg)		TNT (mg/kg)		RDX (mg/kg)	
		Color. on-site	HPLC-acetone	Color. on-site	HPLC-acetone	EIA on-site	HPLC-acetone
D2 Location 1	Surface	593	524	<1	<1	4.0-5.0	1.56
D2 Location 1	0-7.5	341	424	2.9	1.5	0.5-1.5	0.24
		480	344	1.6	1.2	4.5-60	3.27
D2 Location 1	7.5-15	84	78	<1	<1	0.5-1.5	<d
		9.4	8.5	<1	<1	<0.5	<d
D2 Location 2	Surface	452	408	<1	<1	4.0-5.0	<d
D2 Location 2	0-7.5	322	284	<1	<1	3.0-4.5	4.00
		503	411	24	24	4.5-6.0	0.66
D2 Location 2	7.5-15	72	59	<1	<1	3.0-4.5	<d
		48	40	<1	<1	0.5-1.5	<d
D2 Location 3	Surface	599	636	<1	<1	>5.0	<d
D2 Location 3	0-7.5	410	400	4.8	4.6	1.5-3.0	<d
		561	450	12	11	1.5-3.0	<d
D2 Location 3	7.5-15	12	11	<1	<1	1.5-3.0	<d
		125	111	1.9	1.6	0.5-1.5	0.35
D5 Location 1	Surface	55	70	<1	<1	0.5-1.5	0.27
D5 Location 1	0-7.5	41	36	<1	<1	0.5-1.5	<d
		36	36	<1	<1	0.5-1.5	<d
D5 Location 1	7.5-15	7.7	2.1	<1	<1	<0.5	<d
		11	4.0	<1	<1	<0.5	<d
D5 Location 2	Surface	142	141	<1	<1	0.5-1.5	<d
D5 Location 2	0-7.5	57	50	<1	<1	0.5-1.5	<d
		48	35	<1	<1	<0.5	<d
D5 Location 2	7.5-15	2.3	2.3	<1	<1	<0.5	<d
		7.0	5.9	<1	<1	<0.5	<d
D5 Location 3	Surface	66	88	<1	<1	0.5-1.5	<d
D5 Location 3	0-7.5	17	21	<1	<1	0.5-1.5	<d
		10	15	<1	<1	<0.5	<d
D5 Location 3	7.5-15	1.9	1.8	<1	<1	<0.5	<d
		1.9	1.8	<1	<1	<0.5	<d

levels of HMX. However, this cross-reactivity was not sufficient to allow it to be exploited to estimate the concentration of HMX, since even high concentrations of HMX such as 593 mg/kg (D2 location 1, surface) does not produce a D TECH response higher than 4.0–5.0 mg/kg with an intrinsic concentration of RDX of 1.56 mg/kg for the same sample. Roughly, the ratio of cross reactivity can be estimated as being  $10^2$  order of magnitude (Table 1). Using the RDX D TECH EIA test kit for the determination of HMX would lead to a sensitivity decrease of about a factor of 100, meaning a detection limit of approximately 50 mg/kg, which was not acceptable for our purposes.

Results from the analysis of these samples for HMX and TNT are also presented in Table 1. In all cases, HMX was present at concentrations about two orders of magnitude greater than TNT, even though the munition fired at this site had a 70:30 ratio of HMX to TNT. The higher retention of HMX in these near surface soils is probably due to its much lower water solubility (5 mg/L vs. 150 mg/L at 25°C, Burrows et al. 1989) and slower rate of dissolution. In addition, HMX is much less subject to biotransformation or aerobic degradation than is TNT (Grant et al. 1995), and indeed, concentrations of the monoamino transformation products of TNT were often present in concentrations equivalent to those of TNT (App. A).

HMX was present in samples from grid D2, next to tank D, at concentrations about 10 times greater than for those from grid D5, which was about 9 m from the target. With respect to depth, HMX concentrations were highest in the surface samples (over 500 mg/kg for grid D2 and about 100 mg/kg for D5) followed by the 0–7.5-cm segment. HMX concentrations in soil samples from the 7.5–15-cm depth were generally a factor of 5 or more lower than in the 0–7.5-cm depth soils, ranging from about 50 mg/kg for samples from D2 to about 5 mg/kg for samples from D5. These results confirmed what was observed in an earlier study where the depth of contamination was investigated (Thiboutot et al. in press). Thus for this firing range, locating HMX contamination sources can be apparently accomplished best using near-surface soil samples.

### Short-range heterogeneity

In the next phase of the study, soil samples were collected from subgrid D2B to compare the short-range heterogeneity of contaminant distribution to that documented in our earlier study of TNT, DNT and ammonium picrate (Jenkins et al. 1996). Using a sampling protocol identical to the one used in the earlier study, we collected seven discrete samples were collected as shown in Figure 5 for subgrid D2B. These discrete samples were homogenized and analyzed in duplicate, and a composite was prepared and analyzed in triplicate. The results presented in Table 2 and Figure 5 include those from analysis using the on-site colorimetric method, those from laboratory HPLC analysis with the same acetone extracts used for on-site analysis, and those from separate subsamples analyzed at a commercial laboratory

**Table 2. Results from short-range spatial heterogeneity study for HMX with soil samples from subgrid D2B.**

Sample no.	Replicate	HMX (mg/kg)		
		On-site	Acetone HPLC	Method 8330
<b>Discrete samples</b>				
1	a	101	112	220
	b	99	109	120
	mean	100	111	170
2	a	20	18	17
	b	11	13	6.7
	mean	16	16	12
3	a	198	191	320
	b	168	189	250
	mean	183	190	285
4	a	115	144	150
	b	107	139	120
	mean	111	142	135
5	a	313	318	290
	b	329	337	310
	mean	321	327	300
6	a	329	332	390
	b	319	317	420
	mean	324	324	405
7	a	46	69	110
	b	62	82	54
	mean	54	75	82
Discrete sample mean		158	169	198
<b>Composite samples</b>				
a		161	182	240
b		182	180	120
c		185	190	
Composite sample mean		176	184	180

**Table 3. Statistical analysis of HMX (mg/kg) results from discrete and composite samples taken from subgrid D2B for short-range spatial heterogeneity assessment.**

Discrete samples			
Sample	<i>On-site colorimetric</i>	<i>HPLC (acetone)</i>	<i>Method 8330 (acetonitrile)</i>
	Mean	Mean	Mean
1	100 c	111 c	170 b
2	16 a	15.7 a	11.8 a
3	183 d	190 e	285 c
4	111 c	142 d	135 b
5	321 e	328 f	300 c
6	324 e	325 f	405 d
7	54 b	75.2 b	82 a,b
Mean	158	169	198

Numbers designated with the same letter within each column are not significantly different using the least significant difference test at the 95% confidence level.

**Discrete samples**

	ANOVA for on-site and lab analyses		
	<i>On-site colorimetric</i>	<i>HPLC (acetone)</i>	<i>Method 8330 (acetonitrile)</i>
F ratios	257*	478*	26.1*
Error MS	118.5	59.9	1453
Least sign. diff.	25.7	18.3	90.1
Analysis <i>s</i> (RSD) =	10.9 (6.9%)	7.7 (4.6%)	38.1 (19.2%)
Sampling <i>s</i> (RSD) =	123 (77.9%)	120 (71.4%)	135 (68.2%)
( <i>s</i> = standard deviation)			
(RSD = relative standard deviation)			

*Linear correlation analysis for on-site colorimetric vs. lab HPLC (acetone) analysis*  
(*r* = correlation coefficient)

	<i>Slope</i>	<i>Intercept</i>	<i>r</i>
Nonzero intercept	1.027	-15.5	0.996
Zero intercept	0.963	0	

*Linear correlation analysis for on-site colorimetric vs. lab Method 8330 (acetonitrile) analysis* (*r* = correlation coefficient)

	<i>Slope</i>	<i>Intercept</i>	<i>r</i>
Nonzero intercept	0.848	-9.86	0.945
Zero intercept	0.813	0	

**Composite samples**

	<i>On-site colorimetric</i>	<i>HPLC (acetone)</i>	<i>Method 8330 (acetonitrile)</i>
<i>n</i>	3	3	2
Mean value	176	184	180
Standard deviation	12.8	5.19	84.9
RSD	7.3%	2.8%	47.1%

\* Significant at the 99.9% level

using acetonitrile extraction and HPLC analysis (EPA Method 8330, EPA 1995). Statistical analysis is presented in Table 3.

Duplicate analyses conducted using the field colorimetric method and HPLC of the acetone extracts were quite precise and in excellent agreement (Table 3). Mean values for individual samples varied from about 16 mg/kg to over 300 mg/kg. RSDs for analysis were 6.9% and 4.6% for the on-site colorimetric and acetone HPLC results,

respectively, indicating that homogenization of samples using simple, manual procedures was entirely adequate when 20-g subsamples were used for analysis. The correlation coefficient (*r*) for on-site colorimetric and acetone HPLC results was 0.996, and the intercept of the linear model was not significantly different from zero. The slope of the zero intercept linear regression relationship was 0.963, indicating that the two methods gave essentially equivalent results.

Duplicate Method 8330 results by commercial laboratory analysis were much less precise (RSD = 19.2%) than those from the colorimetric and acetone HPLC methods. Apparently any additional homogenization of samples by the commercial laboratory was inadequate to overcome the effect of using a much smaller sample size (2 g) for Method 8330. The correlation coefficient for on-site colorimetric and Method 8330 results was only 0.945 and the slope of the zero intercept regression relationship was 0.813. Some decrease in the correlation coefficient might be expected due to the relatively large random error associated with the Method 8330 results. However, the major reason for the poorer correlation coefficient for this relationship is that the two sets of analyses were done on different subsamples of soil, unlike the on-site colorimetric and acetone HPLC results, which were obtained from the same acetone extract. This is an important observation since validation of results from on-site methods is invariably conducted with different subsamples of soil (splits), and differences observed may be due to actual differences in the analyte content in the subsamples analyzed rather than differences due to the analytical methods.

Mean concentrations for the seven discrete samples analyzed by the on-site colorimetric method ranged from 16 mg/kg to 324 mg/kg. Analysis of variance (ANOVA) indicated that there was a significant difference among samples at the 95% level for all three methods of analysis with *F* ratios of 257, 478, and 27.1, respectively, for the on-site colorimetric, acetone HPLC and Method 8330 (Table 3). The results from ANOVA were used to partition the error from these three sets of data into analytical error ( $S_A$ ) and sampling error ( $S_S$ ) associated with short-range spatial heterogeneity (Table 3). RSDs due to sampling were much higher than those due to analysis and were in quite good agreement for the three sets of data (sampling RSDs ranged from 68.2% to 77.9%). For the on-site colorimetric data, sampling error was over 11 times the error due to analysis. These findings are in excellent agreement with those obtained in our earlier study where the contaminants present were TNT, DNT or ammonium picrate. In that study, four sampling locations yielded data from the seven discrete samples that were sufficiently homogeneous to allow partition of variances into sampling and analytical error, and the  $S_S/S_A$  ratio ranged from about 6 to over 22. This similarity is not surprising since HMX, like TNT, 2,4-DNT and picrate, is a solid at envi-

ronmental conditions and was deposited on site as particles.

Table 3 also includes statistical analyses for the composite sample. The mean values from the analysis of the composite are within 10% of the mean values for the seven discrete samples that make up the composite for each method. The RSDs for the on-site colorimetric and acetone HPLC were 7.3% and 2.8%, respectively. These findings reinforce our earlier conclusion that preparing a homogeneous and representative composite for a set of discrete samples is feasible and does not require sophisticated equipment or exceptional effort or time when 20-g subsamples are used for analysis. The ability to prepare adequate composites for on-site analysis documented here, and elsewhere (Jenkins et al. 1996), is particularly important. Providing adequate characterization of the mean concentration for even a small geographical area using discrete samples would require large numbers of samples and analyses, generally beyond the financial resources available for a specific investigation. However, the use of composites and on-site analysis can effectively deal with this problem.

The much higher RSD for the commercial Method 8330 results (47.1%) agrees with similar results for the discrete samples and is likely due in large part to the 2-g subsample size, which is inadequate to moderate the remaining heterogeneity within the bulk sample. The practice of scooping a subsample from the top of a sample bottle, common in many laboratories, may have exaggerated the heterogeneity problem. Because segregation of particles can occur due to vibration during shipping and storage (even for previously homogenized samples), careful subsampling requires rehomogenization of the entire sample prior to subsampling.

#### **Results for characterization of grid-sized areas for HMX**

In the next phase of the study, the site was divided into sixteen 6- × 6-m square grids between target tanks C and D, and extending in front and beyond the target tanks as shown in Figure 10. Each grid was then divided into 3- × 3-m quadrants that were labeled subgrids A-D; letter designations were assigned in a clockwise fashion starting with the upper left quadrant. Individual analyses for surface soil samples obtained in each subgrid and for grid composites are presented in Appendix A. A diagram showing an overview of the HMX concentrations obtained

from Method 8330 for individual subgrids and grid composites is presented in Figure 10. The Method 8330 results are shown because these data are available for all 16 grids, whereas the on-site results were only obtained for the 10 grids that were jointly sampled by the Canadian and U.S. team. Concentrations ranged from over 1000 mg/kg in several subgrids adjacent to the target tanks to values of about 1 mg/kg at a distance of 20 m in front of the targets.

Table 4 presents the on-site colorimetric results for HMX in the 10 grids where on-site analysis was conducted. Data are shown for individual subgrids, the mean of the four subgrids within a given grid, and the results for analysis of the grid composites. Results from the acetone HPLC analysis and those from Method 8330 are not shown here, but they were very similar. Ratios of highest concentrations divided by lowest concentrations for individual subgrids within a grid (subgrid variability ratio) varied by factors of 2.6 to 18 with a mean ratio of 6.6. This ratio is somewhat inflated, though, by the variability for two subgrids (D9 and D10) with concentrations near or below 50 mg/kg, but even when these values were removed, the mean subgrid variability ratio

was 4.7. These ratios are considerably smaller than observed for the seven core samples taken in a wheel pattern to represent short-range heterogeneity. Those ratios, as found here and in our previous study had values as high as 688 with a mean of about 60 (Table 5). The area-integrated subgrid samples representing mid-range heterogeneity include considerably more soil and, therefore, would be expected to show less variability than the cores. Despite this spatial heterogeneity, the means of the four subgrids and their corresponding grid composites were in good agreement, never differing by a factor greater than about 2. The mean percent difference was 20.2% for all values, and it was only 14.1% when two values with mean concentrations less than 50 mg/kg were excluded. Thus, at this location, subgrid-scale heterogeneity was large, despite taking area integrating samples, but the ability to produce grid-composite samples that represent the arithmetic mean of the four subgrid samples was quite good.

The question remains, however, how closely does a subgrid analytical result represent the mean surface concentration within the subgrid? To address this question we randomly selected 9 subgrids from the 40 discussed above to resample.

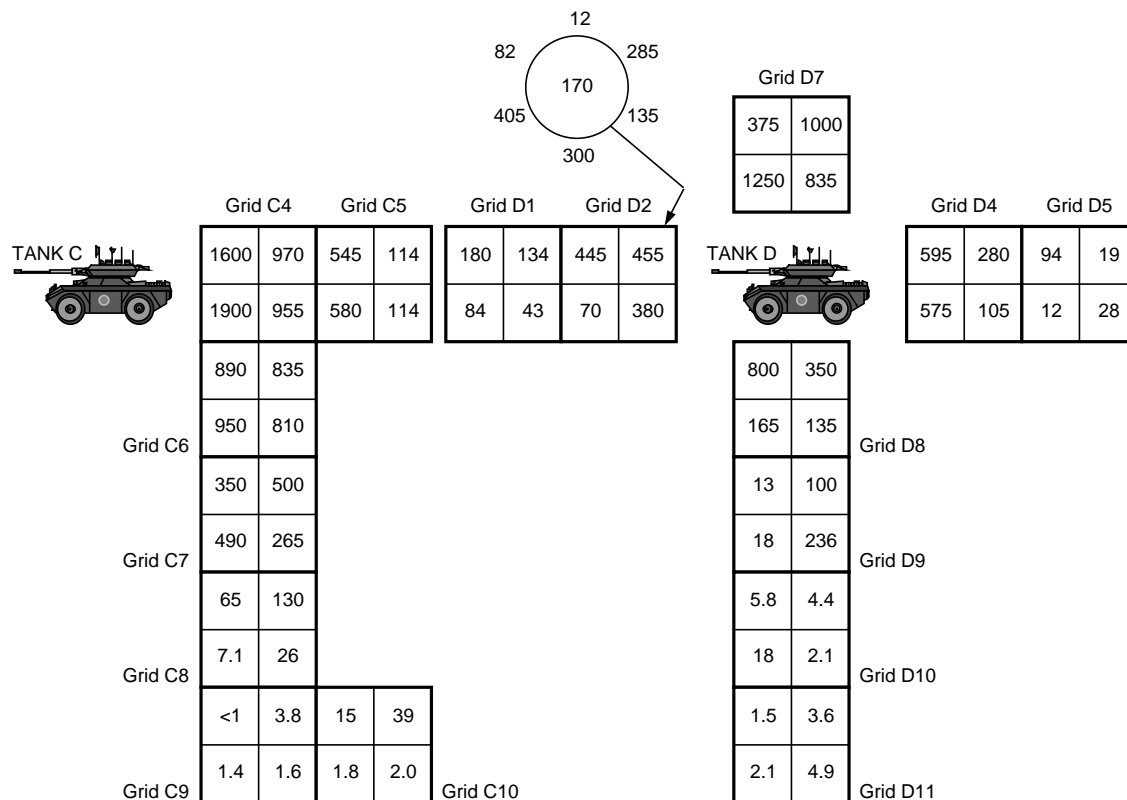

Figure 10. HMX concentrations from commercial laboratory analysis using Method 8330.

**Table 4. Comparison of HMX concentration estimates (mg/kg) using the on-site colorimetric results for individual subgrids, mean of four subgrids, and grid composites.**

Grid no.	Subgrid				Mean	Composite	% Diff.*	Subgrid variability**
	A	B	C	D				
D1	120	121	32	59	83	80	3.6	3.8
D2	279	271	316	41	227	212	6.6	7.7
D4	631	148	254	680	428	479	11.9	4.6
D5	53	33	86	54	57	41	28.1	2.6
D7	209	1000	729	1140	770	812	5.5	5.5
D8	878	286	202	208	394	322	18.3	4.3
D9	10	180	20	14	56	35	37.5	18.0
D10	25	5.1	2.4	6.4	9.8	4.7	52.0	10.4
C4	1910	721	995	2160	1447	1636	13.1	3.0
C5	461	79	129	301	242	180	25.6	5.8
Means					371	380	Mean (all)	6.6
						Mean (except D9 and D10)		4.7
Paired <i>t</i> -test (Composite vs. subgrid mean)							<i>t</i> = 0.382 <sup>†</sup>	
% Diff. Mean (all values)							20.2%	
% Diff. Mean (conc. > 50)							14.1%	

\* Absolute value of [100% - (composite/subgrid mean × 100)].

\*\* Highest subgrid concentration/lowest subgrid concentration.

<sup>†</sup> Composite and mean of subgrids not significantly different at 99.9% confidence level.

**Table 5. Comparison of measures of analytical precision, accuracy and discrete sample representativeness for CFB-Valcartier (CFB-V) results relative to those found for other explosives analytes at Monite (M), Hawthorne (H), and Volunteer (V).**

Sample location	Precision				Accuracy	Local heterogeneity	
	RSD of duplicates		Largest concentration ratio of duplicates		Slope of 0-intercept model On-site vs. lab	Ratio of highest mean concentration vs. lowest for discrete samples	
	On-site	Lab	On-site	Lab		On-site	Lab
CFB-V (HMX)	6.9	19.2	1.818	2.537	0.988	20.2	34.3
CFB-V (TNT)	**	**	1.6	3.6	1.051*	>7	>7
M-1 (TNT)	3.9	11.1	1.157	1.473	0.815	243	315
M-2 (DNT)	23.0	10.0	1.655	1.461	0.350	10.6	33.4
M-3 (TNT)	16.7	6.5	1.822	1.186	1.464	50.0	98.1
H-4 (TNT)	12.5	13.5	1.696	1.986	0.911	69.0	58.1
H-5 (TNT)	3.3	4.9	1.126	1.157	0.847	28.9	29.5
H-6 (picrate)	11.6	11.9	1.500	1.875	0.967	688	43,000
V-7R (TNT)	4.9	5.1	1.265	1.214	0.677	3.8	3.0
V-8 (TNT)	19.7	4.5	1.731	1.185	1.070	53.1	55.6
V-9 (TNT)	4.1	5.1	1.131	1.167	1.032	8.2	5.7
Mean (TNT only)	9.3	7.2	1.418	1.338	0.983	65.1	80.7

\* Slope for model with intercept. Intercept was 0.63, but was found to be statistically significant at the 95% confidence level.

\*\* RSDs could not be computed because many values were less than detection limits for one of the duplicates.

**Table 6. HMX concentrations from on-site colorimetric analysis for subgrids subjected to repeat sampling.**

Subgrid	HMX (mg/kg)		Replicate variability*	Variance	RSD(%)
	Replicate 1	Replicate 2			
D2C	341 <sup>†</sup>	210 <sup>††</sup>	1.6	8581	33.6
D2D	37 <sup>†</sup>	111 <sup>††</sup>	3.0	2738	70.7
D4A	631	444 <sup>††</sup>	1.4	17485	24.6
D7C	729	649 <sup>††</sup>	1.6	3200	8.2
D9B	180	116 <sup>††</sup>	1.6	2048	30.6
D9	20	1.4 <sup>††</sup>	14.2	173	123
D10A	25	4.1 <sup>††</sup>	6.1	218	102
C4A	1910	1170 <sup>††</sup>	1.6	276025	34.0
C4C	995	871 <sup>††</sup>	1.1	7688	9.4
			Mean (all)		48.5
			Mean (conc. > 50)		30.1
			Mean replicate variability (all values)		= 3.6
			Mean replicate variability (conc. > 50)		= 1.7

\* Replicate variability is the higher value/lower value of replicates.

<sup>†</sup> Value randomly selected from two analytical replicates.

<sup>††</sup> Value randomly selected from two subsampling replicates.

This was done two days following the initial subgrid sampling. No precipitation occurred between the period of the initial and subsequent subgrid sampling events. Resampling was conducted in an identical manner to that used for the initial subgrid samples except the regions sampled were offset from the center of the subgrids as shown in Figure 4 for each subgrid resampled.

Thus for the replicate samples, a different 10% of the surface area within a subgrid was sampled. HMX results from on-site analysis for the initial and replicate samples are presented in Table 6. The variability observed for the two replicates for a given subgrid was much lower than observed between subgrids within the grid. Thus even with this enormous short- and mid-range variability present, we were able to reproduce most subgrid values within a factor of two, especially when the HMX concentration was above 50 mg/kg. We did not conduct analysis of variance on these data, however, since the variances obtained for the different subgrids were clearly not homogeneous. In fact, the RSDs obtained for individual subgrids, which ranged from 8.2% to 123%, were inversely related to

concentration (Fig. 11). This relationship is reminiscent of the relationship developed by Horowitz (1982) who demonstrated that analytical standard deviations were a function of concentration for a wide variety of analytical methods and for all types of matrices.

The within-subgrid-scale uncertainty is a combination of analytical error, subgrid subsampling

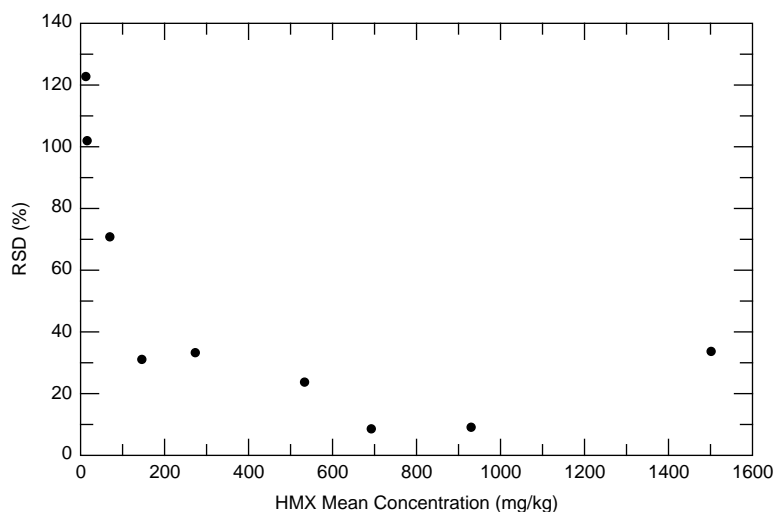

**Figure 11. Dependence of RSDs of duplicate subgrid samples on mean HMX concentration.**

**Table 7. HMX concentrations from on-site colorimetric method for duplicate subgrid subsamples.**

Subgrid	HMX concentration (mg/kg)		Mean	Replicate variability*	Variance RSD	
	Replicate 1	Replicate 2				%
D2C	210	337	273	1.60	8097	32.9
D2D	111	165	138	1.49	1446	27.7
D4A	341	444	393	1.30	5321	18.5
D7C	649	845	747	1.30	19281	18.6
D9B	116	120	118	1.03	9	2.4
D9C	1.4	51	26	6.4	1209	135
D10A	4.2	4.1	4.2	1.02	0	1.7
C4A	1170	1260	1220	1.08	4151	5.3
C4C	984	871	928	1.13	6432	8.6
Mean replicate variability (all values)				5.15		
Mean replicate variability (values >50 mg/kg)				1.24		
Mean RSD (all values) = 27.9%						
Mean RSD (conc. > 50 mg/kg) = 16.3%						

\* Replicate variability is the higher value/lower value for replicates.

error, and the sampling error due to spatial heterogeneity in analyte distribution within the subgrid. To assess the magnitude of these various contributions to the total uncertainty, a series of replicate subsamples were collected. For the nine subgrids that were resampled, duplicate pile subsamples were collected and analyzed by the on-site colorimetric method (Table 7). For eight of the nine subgrids, the ratios (higher duplicate value divided by the lower value) ranged between 1.02 and 1.60, with a mean of 1.24 indicating that we were able to reproducibly obtain subgrid subsamples. The replicates for subgrid D9C differed by a factor of 36.4, but the concentrations for both replicate samples were low. This anomalous result appears atypical. With the contributions of spatial heterogeneity excluded as a source of uncertainty, the results were in very good agreement. An ANOVA was not conducted for this data set since variances were not homogeneous; however, RSD values were much more normally distributed and were once again inversely related to concentration.

Taking the results from Tables 6 and 7 together, we can compare the relative magnitudes of uncertainty due to spatial heterogeneity and subsampling error. The mean RSD estimate when sampling a subgrid with concentrations above 50 mg/kg was 30.1% (Table 6). This can be considered an estimate of total uncertainty due to the

combination of spatial heterogeneity of analyte distribution, subsampling error, and error due to analysis. Likewise the mean RSD in Table 7 for duplicate subsamples for samples with concentrations above 50 mg/kg was 16.3% and is due to the contribution of subsampling error and analysis error. From a series of measurements on a single extract, the RSD for analysis was only 3.2%, so the major portion of this 16.3% estimate is associated with subsampling and extraction. Based on a comparison of the variances associated with RSDs of 30.1% and 16.3%, only about 30% of the total variance is associated with subsampling and analysis while 70% is due to spatial heterogeneity within the subgrid. It is interesting to compare this result with those from the seven core samples in a wheel pattern, both here and in the earlier studies (Jenkins et al. 1992). The mid-range spatial heterogeneity error for area integrated samples was only a little more than twice as large as the subsampling plus analytical error, whereas the comparable relationship for the core samples yielded a difference of about 10 times. Clearly the area integrated samples do a better job of minimizing error due to spatial heterogeneity. We should note that area integrated samples can be obtained by a variety of protocols which might be equal to or better than the circular path used in this study.



### Comparison of HMX concentration estimates from on-site colorimetric and laboratory methods for subgrid and grid-composite samples

HMX concentration estimates were obtained for all subgrid and grid-composite samples: 1) using the on-site colorimetric method (Jenkins et al. 1995), 2) using HPLC analysis at CRREL for the same acetone extracts employed for on-site analysis, and 3) at an independent commercial laboratory using EPA Method 8330 which is an HPLC method with acetonitrile extraction of sepa-

rate subsamples of soil (App. A). A few of the acetone extracts were also analyzed by gas chromatography with an electron capture detector (GC-ECD), primarily for analyte confirmation.

Results for the on-site and acetone HPLC analyses for this group of 106 samples were compared using a paired  $t$ -test and linear correlation analysis. The  $t$  value was 0.0596, indicating that the results from the two methods were not significantly different at the 99.9% confidence level. From linear correlation analysis, the correlation coefficient for the model with intercept was 0.992, the

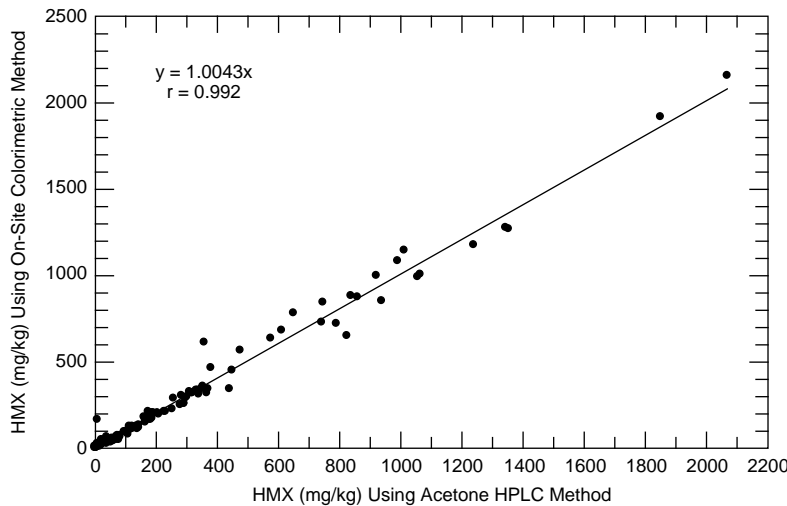

Figure 12. Correlation analysis of HMX concentration estimates from the colorimetric on-site method with those from HPLC analysis of the same acetone extracts.

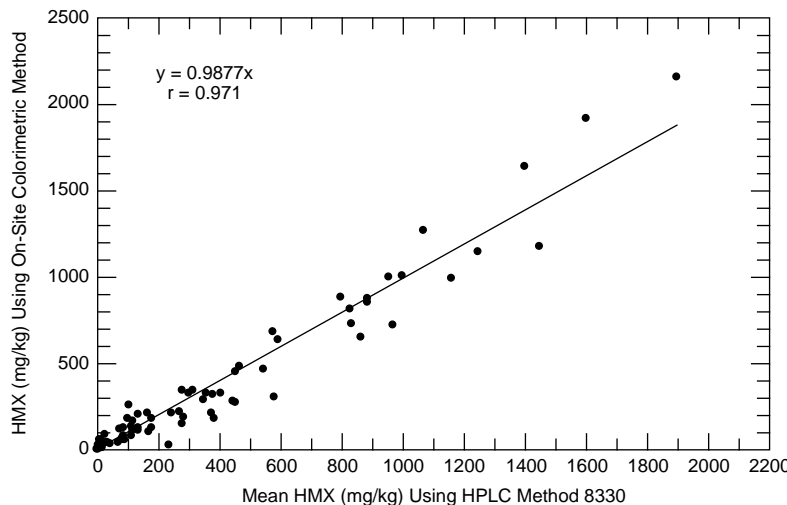

Figure 13. Correlation analysis of HMX concentration estimates from the colorimetric on-site method with those from EPA Method 8330 using separate subsamples.

slope of the relationship was 1.008 and the intercept was  $-2.77$ . The intercept was not significantly different from zero ( $t = 0.43$ ) at the 99.9% confidence level. The linear model with zero intercept had a slope of 1.004 (Fig. 12). This excellent correlation between these two independent methods of instrumental determination and a slope that matches the theoretically expected value of 1.00, verifies that the on-site method is providing concentration estimates for HMX that are equivalent to the HPLC estimates.

Results for the on-site method were also compared with those from the independent commercial laboratory (Method 8330). There were only 76 samples that could be correlated because duplicates were not related one-to-one as they were above where identical extracts were analyzed. The  $t$  value from the paired  $t$ -test was 1.516, indicating that the results from the two methods were not significantly different at the 95% confidence level. From the correlation analysis, the slope of the model with intercept for this analysis was 1.016 with an intercept of  $-25.0$  and a correlation coefficient of 0.972. The intercept was not significantly different from zero ( $t = 1.51$ ) at the 95% confidence level so the zero intercept model was obtained. The slope of this relationship was 0.988 (Fig. 13). The correlation between these two methods is also quite good, but not as good as that shown above where the same extract was analyzed by two

methods. Here, separate subsamples were analyzed and subsampling heterogeneity increased random error. The fact that Method 8330 specifies only 2-g samples would also tend to increase the impact of heterogeneity. Nevertheless, the slope of this relationship is not significantly different from 1.00 at the 95% confidence level which shows that the two methods are not systematically biased. It is clear that the 30-minute on-site extraction with acetone provided equivalent extraction efficiency for these soils to that for Method 8330, which is an 18-hour ultrasonic extraction using acetonitrile.

### Concentration estimates for TNT in subgrid and grid-composite samples

As noted earlier, TNT concentration estimates using on-site methods were much lower than for HMX at CFB-Valcartier. Samples ( $n = 83$ ) used to assess short-range heterogeneity, as well as subgrid and grid-composite samples were also analyzed for TNT using 1) an on-site colorimetric method (EnSys), 2) an on-site immunoassay

method (D TECH), 3) the acetone HPLC method described for HMX analysis, and 4) Method 8330 (Table 8). A diagram of the site with on-site colorimetric results is presented in Figure 14. Of these, concentration estimates for 31 samples were below the detection limit of 0.3 mg/kg by Method 8330 (0.3 mg/kg is also the detection limit for the acetone HPLC method), seven had concentrations between 0.3 mg/kg and the 0.5-mg/kg detection limit for the D TECH method, nine had concentrations between 0.6 and 0.9 mg/kg, the detection limit for the Ensys colorimetric method, and 36 had concentrations at or above 1.0 mg/kg.

An assessment of the apparent rate of false positives and false negatives produced by the on-site and acetone HPLC methods, relative to the Method 8330, results is presented in Table 9. Of the 36 samples with concentration estimates at or above 1.0 mg/kg by Method 8330, 32 were positive using the EnSys colorimetric method and only four were apparent false negatives. Likewise for the D TECH immunoassay method, 45 samples were found to be above the detection limit of 0.5 mg/kg, and of these, 10 were classified as appar-

#### DREV TNT

- $\bar{X}$  Mean of all samples in grid, less duplicates
- Location of sample
- Location of duplicate ( $d$ )

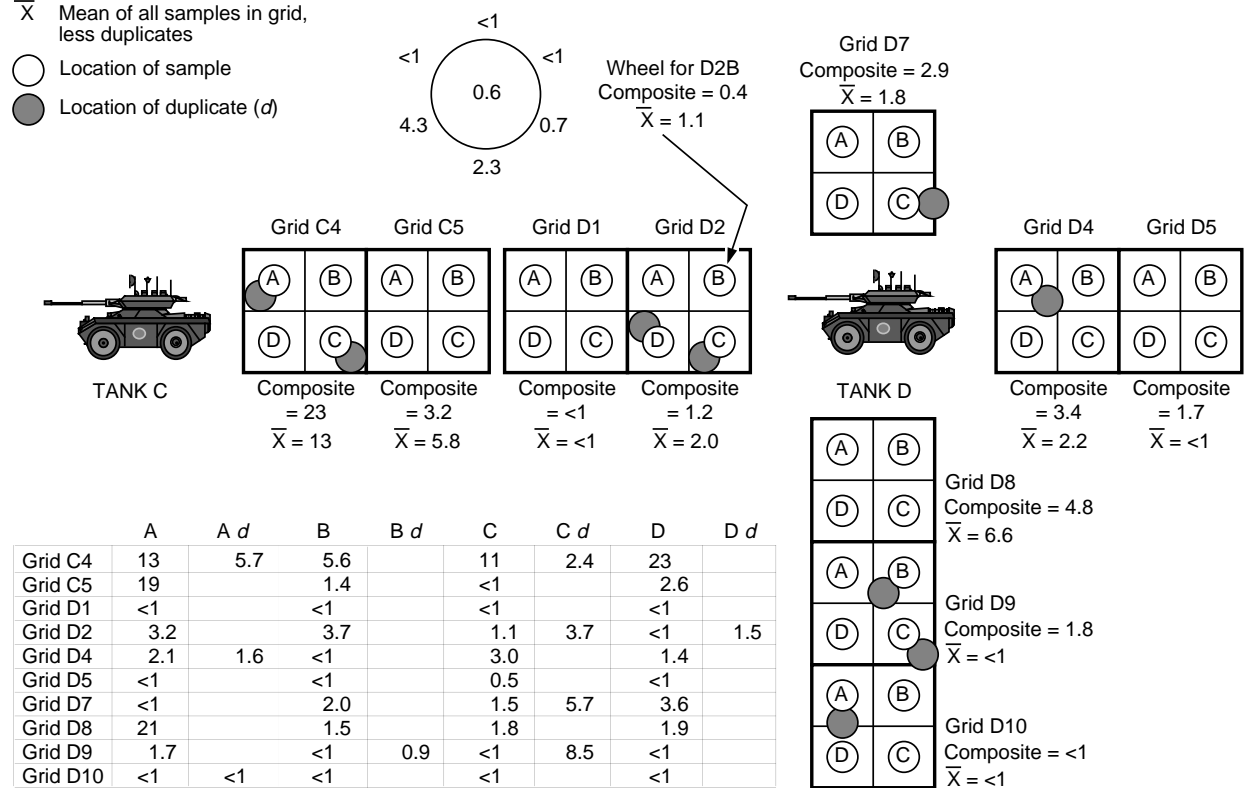

Figure 14. Sampling area at CFB-Valcartier firing range site, showing TNT concentrations from on-site colorimetric analyses.

**Table 8. Comparison of concentration estimates for TNT from various on-site and laboratory methods.**

Sample	TNT (mg/kg)		Acetone-HPLC	Method 8330
	On-site (colorimetric)	On-site (EIA)		
D1A	<1	0.5–1.5	<0.3	<0.3
D1B	<1	0.5–1.5	<0.3	0.6
D1C	<1	<0.5	<0.3	<0.3
D1D	<1	<0.5	0.8	<0.3
D1Comp a	<1	<0.5	<0.3	0.3
D1Comp b	<1	0.5–1.5	<0.3	0.3
D2A a	6.5	3.0–4.0	5.6	<0.3
D2A b	<1	3.0–4.0	0.3	<0.3
D2B a	5.6	4.0–5.0	5.1	1.0
D2B b	1.8	1.5–3.0	1.3	0.6
D2C a	2.2	<0.5	<0.3	3.8
D2C b	<1	1.5–3.0	1.0	3.8
D2CC 1	3.4	3.0–4.0	2.8	1.1
D2CC 2	4.0	3.0–4.0	2.9	3.5
D2D a	<1	<0.5	<0.3	1.1
D2D b	<1	<0.5	1.0	0.4
D2DD 1	1.0	<0.5	<0.3	0.7
D2DD 2	1.9	<0.5	1.5	1.1
D4A	2.1	0.5–1.5	0.7	1.3
D4AA 1	1.5	1.5–3.0	0.4	0.4
D4AA 2	1.7	<0.5	1.0	0.4
D4B	<1	<0.5	<0.3	0.7
D4C	3.0	<0.5	1.3	0.6
D4D	1.4	<0.5	0.7	0.6
D4Comp a	3.3	1.5–3.0	3.7	0.7
D4Comp b	3.4	0.5–1.5	2.2	0.6
D5A a	<1	<0.5	<0.3	<0.3
D5A b	<1	<0.5	<0.3	<0.3
D5B a	<1	<0.5	<0.3	<0.3
D5B b	<1	<0.5	<0.3	<0.3
D5C a	<1	<0.5	<0.3	<0.3
D5C b	<1	<0.5	<0.3	<0.3
D5D a	<1	<0.5	<0.3	<0.3
D5D b	<1	<0.5	<0.3	<0.3
D5Comp a	2.7	0.5–1.5	1.9	<0.3
D5Comp b	<1	<0.5	<0.3	<0.3
D7A	<1	0.5–1.5	1.0	1.0
D7B	2.0	1.5–3.0	1.7*	1.8
D7C	1.5	0.5–1.5	0.9	1.7
D7CC 1	2.2	<0.5	0.9	1.0
D7CC 2	9.1	3.0–4.0	7.3	1.0
D7D	3.6	3.0–4.0	2.1	8.8
D7Comp a	2.5	1.5–3.0	1.4	3.7
D7Comp b	3.3	1.5–3.0	2.1	21
D8A	21	16–20	17	21
D8B	1.5	1.5–3.0	0.7	1.1
D8C	1.8	1.5–3.0	1.1	1.5
D8D	1.9	1.5–3.0	1.9	<0.3
D8Comp a	6.2	4.0–5.0	4.1	5.6
D8Comp b	3.4	4.0–5.0	2.2	9.7
D9A	1.7	<0.5	<0.3	<0.3
D9B	<1	<0.5	<0.3	0.4
D9BB 1	1.2	<0.5	<0.3	<0.3
D9BB 2	<1	<0.5	0.4	<0.3
D9C	<1	<0.5	<0.3	111
D9CC 1	<1	<0.5	<0.3	<0.3
D9CC 2	17	12–16	15	<0.3
D9D	<1	<0.5	<0.3	<0.3

**Table 8. (cont'd)**

Sample	TNT (mg/kg)		Acetone-HPLC	Method 8330
	On-site (colorimetric)	On-site (EIA)		
D9Comp a	1.7	<0.5	<0.3	<0.3
D9Comp b	1.9	<0.5	<0.3	1.0
D10A	<1	<0.5	<0.3	<0.3
D10AA 1	<1	<0.5	<0.3	<0.3
D10AA 2	<1	<0.5	<0.3	<0.3
D10B	<1	<0.5	<0.3	<0.3
D10C	<1	<0.5	<0.3	<0.3
D10D	<1	<0.5	<0.3	<0.3
D10Comp a	<1	<0.5	<0.3	<0.3
D10Comp b	<1	<0.5	<0.3	<0.3
C4A	13	2–15	11	7.5
C4AA 1	6.5	4.0–5.0	5.6	6.5
C4AA 2	4.8	4.0–5.0	3.9	2.6
C4B	5.6	4.0–5.0	4.3	16
C4C	11	4.5–9.0	15.9*	4.8
C4CC 1	3.0	4.0–5.0	2.5	4.3
C4CC 2	1.7	4.0–5.0	3.4	4.7
C4D	23	12–15	20	10
C4Comp a	19	4.5–16	16	3.9
C5A	19	12–15	18	0.8
C5B	1.4	1.5–3.0	1.9*	4.8
C5C	<1	0.5–1.5	<0.3	0.4
C5D	2.6	3.0–4.0	2.6*	73
C5Comp a	4.8	4.0–5.0	4.3	6.2
C5Comp b	1.6	0.5–1.5	1.2	4.9

\* Data from GC–ECD analysis.

**Table 9. Apparent false positives and false negatives relative to Method 8330 results for TNT.**

Method	Detection limit (mg/kg)	Apparent false positives		Apparent false negatives	
		No. pos.* on-site	No. confirmed Method 8330	No. pos. by† Method 8330	No. detected on-site
EnSys Colorimetric	1.0	48	41	36	32
D TECH Immunoassay	0.5	44	38	45	35
Acetone HPLC	0.3	49	42	52	42

\* Concentration above detection limit of method.

† Concentration by Method 8330 was above the detection limit of associated confirmatory method

ent false negatives. To put this in perspective, though, 52 samples gave Method 8330 concentration estimates above the 0.3-mg/kg detection limit of the acetone HPLC laboratory method, which used the same acetone extracts as used by the EnSys and D TECH methods. Of these, 10 were classified as apparent false negatives by acetone HPLC.

In terms of false positive analysis, the EnSys method resulted in a positive response for 48 samples. Of these, 41 were confirmed positive by Method 8330 while seven were non-detects. In a similar manner, the D TECH method had 44 positive responses and 38 were confirmed by Method 8330, while six were non-detects. The acetone HPLC method resulted in 49 positive responses

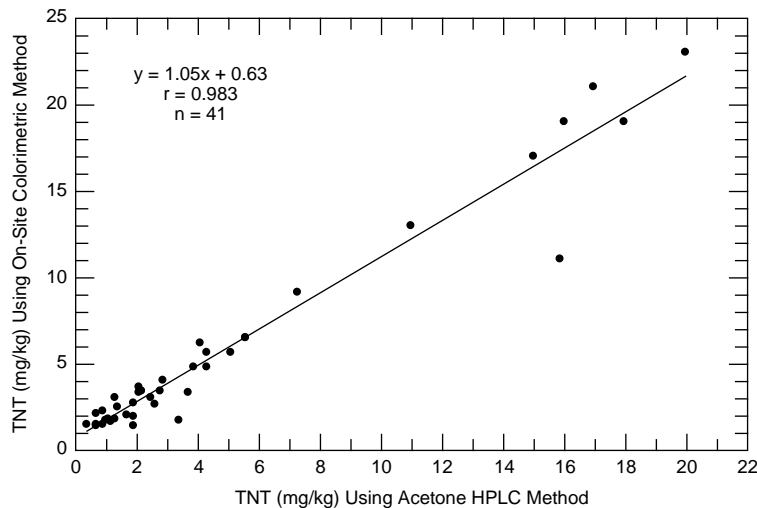

Figure 15. Correlation analysis of TNT concentration estimates from the colorimetric on-site method with those from HPLC analysis of the same acetone extracts.

while 42 were confirmed by Method 8330 and seven were classified as false positives.

The agreement of samples with values above detection using on-site methods, relative to Method 8330, has been commonly used to compute the percentage of false positives and false negatives. Usually the lack of agreement has been attributed to a failure on the part of the on-site method. Yet if we look carefully at the data in Table 8, clearly this interpretation is misleading. For example, consider sample D9C where Method 8330 gave a concentration of 111 mg/kg, the highest value found, whereas the EnSys, D TECH and acetone HPLC were all non-detects. Clearly this is not a failing of the on-site methods, since three independent methods using the same extract concur that the concentration of TNT is low. More likely this is due to a small chunk of TNT being present in the subsample used for Method 8330 analysis. In fact the Method 8330 result presented for TNT was actually a mean of duplicates; the individual determinations on separate subsamples were 220 mg/kg and 1.6 mg/kg, respectively. In a similar manner, if we look at sample D9CC2, the Method 8330 result for this sample was <0.3 mg/kg while those for the EnSys, D TECH and acetone HPLC were 17 mg/kg, 12–16 mg/kg, and 15 mg/kg, respectively. This sample came from the same subgrid as sample D9C discussed above. Thus both spatial and subsampling heterogeneity must be kept in mind when attempting to assess false positives and false negatives with on-site methods for explosives.

Correlation analysis was also conducted on the numerical results from the on-site colorimetric and acetone HPLC analyses for the 41 subgrid and grid-composite samples where both analyses resulted in a value above detection limits (Fig. 15). The slope of the linear model was 1.05 with an intercept of 0.63; the correlation coefficient was 0.975. The slope was not significantly different from 1.0 at the 95% confidence level, while the intercept was significantly different from zero at the 95% confidence level. This indicates that the two methods provide very comparable results, with a very slight positive bias in the results from the colorimetric method. This slight positive bias may be a result of our decision to subtract twice the initial absorbance from the final absorbance, when computing the TNT concentration using the colorimetric result (Jenkins 1990).

EnSys recommends subtracting four times the initial absorbance from the final absorbance (EPA Method 8515) and if we computed it using this approach, the bias may have been eliminated. However, we chose the factor of two, rather than four, to guard against false negative results. Correlation of the on-site colorimetric results with those from Method 8330 was not conducted due to the large problem with heterogeneity discussed earlier.

Correlation analysis was also conducted between the results from the D TECH EIA method with those from acetone HPLC (Fig. 16). To conduct this analysis, we paired the result of the acetone HPLC analysis with the midpoint of the range produced by the D TECH test for the 40 samples, where both methods produced a result above detection limits. When this was done, the slope of the linear model was 0.69 with an intercept of 1.24 and a correlation coefficient of 0.91. Neither the slope or the correlation was as satisfactory as with the colorimetric method.

### Co-contaminants

At sites contaminated with TNT, co-contaminants may include biotransformation products (2-amino-DNT, and 4-amino-DNT), photodegradation products (TNB), and manufacturing by-products (DNT and DNB). In several of the grids sampled at this site, we found both isomers of amino-DNT, indicating that biotransformation of TNT is taking place and this process likely con-

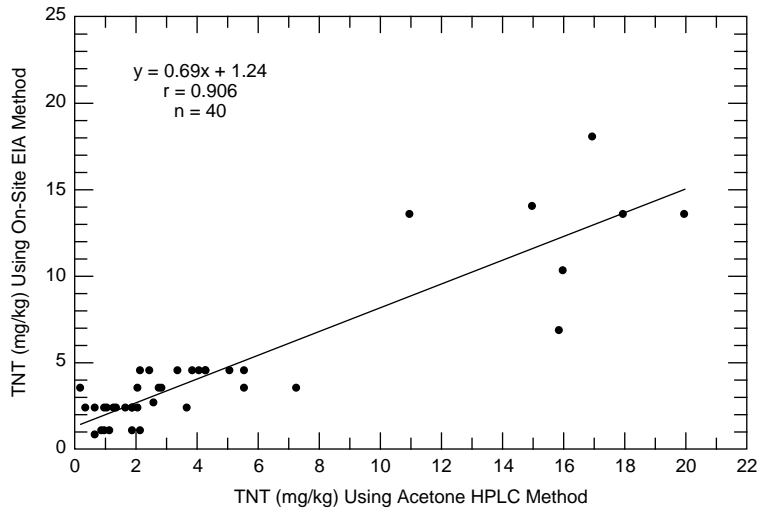

Figure 16. Correlation analysis of TNT concentration estimates from the EIA on-site method with those from HPLC analysis of the same acetone extracts.

tributes to the much lower concentrations of TNT compared to HMX. The highest concentrations of the amino-DNTs were about 10 mg/kg behind tank D (grid D7) where the soil was moist and appeared to have a higher organic content. Elsewhere the amino-DNTs were generally in the 1–2 mg/kg range. Formation and further transformation and conjugation of the amino-DNTs is probably a major reason that TNT levels are much lower than HMX in the soils at CFB-Valcartier.

The lab analysis sporadically detected 2,4-DNT, sometimes at higher concentrations than TNT (higher than would be expected if the source of the 2,4-DNT was as an impurity in TNT). We previously observed high concentrations of 2,4-DNT at open burning/open detonation sites where excess propellant was burned (2,4-DNT is an ingredient in some propellant compositions). The disagreement was extreme in the DNT concentration estimates for some subsamples of the same sample. For example, in the composite of grid D2, the estimates were <0.3 and 24 mg/kg for the two lab subsamples. Such large heterogeneity implies that the contaminant is particulate. The manufacturing by-product DNB was not detected, nor was TNB.

RDX is not a major contaminant in military grade HMX. However, RDX is the major component in Composition A5, the booster used for the 66-mm M72 rocket. Soil analysis, however, revealed only traces of RDX compared to the levels of HMX on site. Often the concentrations of RDX were less than method detection limits and were

almost always under 2 mg/kg. An RDX value of 7 mg/kg was found for subgrid C4D, where the HMX concentration was 2070 mg/kg and an RDX concentration of 11 mg/kg was observed for one replicate of the composite sample for grid D7. The RDX concentrations were never sufficiently high to interfere in the colorimetric determination of HMX.

### Water analysis

We also found high concentrations of HMX in the few water samples collected at CFB-Valcartier (Table 10). The highest HMX concentrations were in the well water (295 µg/L). TNT concentrations were about 100 times lower than HMX, a similar ratio to what we observed in soil. These water samples were not chemically preserved, and

when separate subsamples were subsequently analyzed at CRREL, HMX concentrations were similar to those found at CFB-Valcartier, but TNT was not detected in the well water samples. However, the amino-DNTs were detected, which adds more evidence that microorganisms capable of transforming TNT are present at this site.

The concentration ratio of HMX to RDX in the well water was approximately six; however, we only sporadically detected RDX in soil. When RDX was detected in soil, the concentrations were generally near detection limits and were always at much lower concentrations than HMX. In the sandy soils encountered at CFB Valcartier, RDX may be more susceptible to leaching than HMX, perhaps due to a greater rate of dissolution. Although RDX is about 10 times more water soluble than HMX, the kinetics of dissolution under environmental conditions are not well defined. The eight-membered ring of HMX has been reported to be less susceptible to biotransformation than the six-membered ring of RDX (Spanggord et al.

Table 10. Concentrations of HMX, RDX, and TNT detected in groundwater and surface water samples at CFB-Valcartier.

	Concentration (µg/L)		
	HMX	RDX	TNT
Well water	295 (±2.0)	46 (±2.0)	3.1 (±1.1)
Surface water 1	125	<d	<d
Surface water 2	31.7	1.8	<d

1983, McCormick et al. 1984), but biodegradation of both are thought to be primarily anaerobic processes.

### **Analysis of explosives residues remaining on metallic debris**

Although the site had been “cleared” by safety personnel prior to site characterization, the ground was littered with small pieces of metallic debris from detonated projectiles, empty rocket bodies, fins and booster cups. A 7-g sample of metallic debris was collected and subsequently extracted with acetone in the CRREL laboratory. RP-HPLC analysis revealed the presence of HMX and TNT at 50 mg/kg and 0.1 mg/kg, respectively. The higher residual HMX is probably due to its lower aqueous solubility and rate of dissolution compared with TNT. The concentrations associated with this debris do not seem to be high enough to be the major mode of contamination for the soils at CFB-Valcartier, but does demonstrate that not all the explosive charge is consumed during detonation.

### **GC comparisons**

The GC proved to be useful for analyte confirmation following HPLC analysis, especially for confirmation of DNT. For example, when acetone extracts were analyzed by HPLC using the LC-CN column, a peak eluting just prior to the retention time for TNT and corresponding to the retention time for DNT was observed in several samples (Fig. 8). Because of the close retention times for these two analytes on LC-CN, the analytes are not resolved if one analyte is at a much higher concentration than the other. Based on site characterization conducted prior to this study, the presence of DNT was not anticipated; hence confirmation was required. Analysis of the acetone extracts by GC confirmed the presence of DNT, and permitted quantification of the lower concentration analyte (Fig. 9).

## **SUMMARY AND CONCLUSIONS**

### **On-site methods**

The results of this study provide information in a number of areas that should be quite useful for planning site characterization activities at explosives-contaminated areas. First, the utility of on-site methods for obtaining concentration estimates for TNT and HMX is clearly demonstrated. Colorimetric methods for HMX and TNT pro-

vided concentration estimates that were essentially equivalent to those from the standard laboratory method. Linear correlation analysis for HMX results from the on-site colorimetric method with a laboratory HPLC method using the same acetone extract resulted in a slope of 1.008 and a correlation coefficient of 0.992; the intercept was small and nonsignificant at the 95% confidence level. Correlations of the on-site HMX results with those from Method 8330 conducted at an independent commercial laboratory were also good, but less so. The slope of the model with intercept for this analysis was 1.016 with an intercept of -25.0 and a correlation coefficient of 0.972. The poorer relationship found here was attributed to the analysis of separate subsamples of soil, rather than the analysis of aliquots of the same extract used in the former comparison.

For TNT, a similar correlation of the on-site colorimetric result with that from HPLC analysis of the same acetone extract resulted in a slope of 1.05, and intercept of 0.63 (significant at the 95% confidence level), and a correlation coefficient of 0.975. No correlation with Method 8330 results was obtained due to substantial variability encountered among subsamples for TNT, which was present at much lower concentrations than HMX. This result indicates that care should be used when comparing results from on-site and laboratory analyses conducted with separate subsamples, unless soils are homogenized carefully before splitting.

It is important to remember that the results from these on-site colorimetric methods were available to site investigators the day following soil sample collection, allowing their use to adjust site activities to reflect an increasing knowledge of contaminant distribution. The use of EIA RDX tests was abandoned after the first set of samples, since HMX is present as the main contaminant and the cross-reactivity for this nitramine is not adequate to provide sensitive detection. The comparison of results from the D TECH EIA method and those from acetone HPLC for TNT determination led to a slope of the linear model of 0.69 with an intercept of 1.24 and a correlation coefficient of 0.91, which indicates a somewhat poorer correlation between the two methods compared to the excellent general correlation observed between the colorimetric and acetone HPLC methods.

### **Short-range spatial heterogeneity**

Short-range spatial heterogeneity of HMX concentrations at the CFB-Valcartier antitank range

was substantial and similar in magnitude to those documented in an earlier study of TNT, DNT, and ammonium picrate (Jenkins et al. 1996). Using the results from the on-site HMX method, the standard deviation due to sampling error was 11 times that due to analysis when discrete core samples were used for characterization. The use of on-site sample homogenization and compositing of discrete soil samples and the use of 20-g subsamples of soil for analysis were shown to minimize the problems caused by short-range spatial heterogeneity.

### **Midscale spatial heterogeneity**

The degree of midscale spatial heterogeneity of explosives contamination was assessed for the first time at CFB-Valcartier. The site was divided into sixteen 6- × 6-m square grids, and each grid was further subdivided into four 3- × 3-m subgrids. Analysis of replicate samples from nine randomly selected subgrids indicated that we were generally able to reproduce results within a factor of two, using a simple integrating method that samples about 10% of the surface within the subgrid.

The variability of the concentrations in the four subgrids making up a geographically defined grid area was also estimated and found to average about 5 when concentrations were above 50 mg/kg. Even in the presence of this substantial spatial heterogeneity, we were able to produce grid-composite samples from the four area integrated subgrid samples that were in good agreement with the arithmetic mean of the four. The mean difference observed for the 10 grids where this was evaluated was about 20% with values never differing by a factor greater than about 2.

### **Accumulation of explosives residues at an active antitank firing range**

This study documented, apparently for the first time, the levels of explosives residues that accumulate in the soil at an active firing range. HMX accumulated in the surface soils to a much greater degree than did TNT, the other major component in the melt-cast explosives used in the 66-mm M72 rocket fired at CFB-Valcartier. Concentrations of HMX as high as 2000 mg/kg were found in surface soil near to the targets. This concentration appears to be too high to be due to residues from detonations and may have resulted from rupture of unexploded rockets and ejection of particles of the explosives. The much lower accumulation of TNT in these soils is probably due to

the rapid biotransformation of TNT to amino-DNTs, and rapid leaching or chemi-sorption (binding) of the amino metabolites (Thorne and Leggett in press).

### **CONCLUDING REMARKS**

The ultimate goal of site characterization activities is to provide sufficient information so that informed decisions can be made about the development of an optimal approach for remediation when it is required. To accomplish this goal, potentially contaminated sites are generally divided into small geographically defined units (grids), and samples are collected and analyzed to characterize the concentrations of contaminants within these zones. The dimensions of these grids can range from tens of meters on a side to hundreds of meters on a side and often a single core sample is collected within the grid, divided into depth intervals, and the various depth related samples analyzed at an off-site commercial laboratory. Decisions regarding the need for cleanup are made by comparing contaminant concentrations obtained from sample analysis to action levels determined by risk assessment.

An unstated assumption of this approach is that the concentration of contaminants of interest in the samples collected and analyzed adequately represents the average concentration of those contaminants at the collected depths within grid boundaries. Discussion with both the personnel conducting site characterization activities and those within the government that oversee these activities indicate that some of the shortcomings of this approach are recognized, but that financial considerations preclude the analysis of sufficient numbers of samples to adequately address the problem. The high cost of laboratory analyses, in particular, is often quoted as an impediment to the analysis of the required number of samples to truly characterize the distribution of contaminants.

Explosives represent a fairly unusual set of environmental contaminants. The most commonly encountered secondary explosives are solids at environmental temperatures and were generally released into the environment as particulates. Thus the bulk of contamination generally resides in near surface soils. These explosives have low vapor pressures and hence no special precautions are needed during sample collection to mitigate vapor losses. They are relatively polar, particularly for neutral organic compounds, and do not



sorb strongly to soils by hydrophobic interactions. The major explosives contaminants, TNT and RDX, have aqueous solubilities in the 50–150 mg/L range and, from a kinetic point of view, dissolve slowly into aqueous solution. Because of these factors, high concentrations of these compounds can persist in near-surface soils for decades. Once they are dissolved in water, though, they can migrate rapidly through the unsaturated zone to the water table and form plumes in underlying aquifers miles in length.

The particulate nature of these contaminants in near surface soils leads to substantial spatial heterogeneity in distribution. Characterization of the short-range spatial heterogeneity was conducted both here and in an earlier study (Jenkins et al. 1996). These studies demonstrate that concentration estimates for discrete samples collected less than a meter apart can vary by factors ranging from 3 to 43,000, with a median value of about 50. Thus, the use of a single discrete sample to represent even a small geographical area will lead to enormous uncertainty. Using on-site homogenization of several discrete samples followed by compositing, however, produced a sample that was much more representative of the mean concentration over the area sampled.

Midscale heterogeneity was also assessed in this study. Using an “area-integrated” sampling scheme, we were able to reproduce concentration estimates for 3- × 3-m sized subgrids quite well (Table 7). Even with this scheme, though, the ratio of the highest concentration divided by the lowest concentration among the four 3- × 3-m subgrids, within a 6- × 6-m grid, averaged about 5 (Table 4). Combining the samples from the four “area integrated” subgrid samples to form a grid-

composite proved to be an efficient way to produce a representative sample for the grid.

A number of on-site methods for TNT and RDX have been developed. Here we assessed colorimetric methods for TNT and HMX, and an enzyme immunoassay method for TNT. The accuracy of the colorimetric methods was evaluated by comparison with a laboratory reference method and the results for both TNT and HMX were quite impressive. The slopes of the linear models were 1.008 and 1.05 for HMX and TNT, respectively, with correlation coefficients of 0.992 and 0.975. Intercepts were also quite low indicating that the methods could be used with confidence down to their detection limits of about 1 mg/kg. The results for the colorimetric TNT method agree with those presented elsewhere (Jenkins et al. 1996, Myers et al. 1994). The enzyme immunoassay method for TNT produced results in ranges in contrast to the colorimetric method that provides a quantitative result. Correlation analysis between the midpoint of the range established by this method with laboratory analyses was not quite as good as that for the colorimetric method, but entirely adequate.

By combining the ability to produce representative samples via on-site homogenization and compositing with the ability to obtain accurate analytical estimates using inexpensive on-site methods, site investigators can effectively overcome the problem of spatial heterogeneity for explosives-contaminated areas.

This study reports concentrations of explosives on an active firing range. Very little information of this type is currently available, particularly where HMX is the major potential contaminant. Firing ranges are found on many military bases

**Table 11. Fractionation of total error into analytical and sampling components.**

<i>Sampling location</i>	<i>Standard deviation</i>				<i>Ratio</i>	
	<i>Analytical</i>		<i>Sampling</i>		<i>Sampling/analytical</i>	
	<i>On-site</i>	<i>Lab</i>	<i>On-site</i>	<i>Lab</i>	<i>On-site</i>	<i>Lab</i>
Hawthorne location 4 (TNT)	217	265	1,970	2,150	9.1	8.1
Hawthorne location 5 (TNT)	5.3	11.0	121	131	22.8	11.9
Volunteer location 7 (TNT)	—*	7,680	—*	19,800	—*	2.6
Volunteer location 7R (TNT)	5,120	6,320	24,700	27,600	6.1	4.4
Volunteer location 9 (TNT)	1.0	1.0	10.4	12.4	10.4	12.4
CFB-V (HMX)	10.9	38.1	123	135	11.3	3.5

\* Data unavailable.

worldwide and are considered as operational sites. In the long run, this study might help to establish recommendations that could minimize the impact of such an activity on the environment. Firing practices are an important operational activity for the military and therefore cannot be banned. In the present case, the major contamination is found in the top layer of the soil and simple remedial actions could be proposed in order to minimize the potential for leaching of the contaminants to the groundwater. In fact, such remedial action will be carried out in the near future at CFB-Valcartier, based on results obtained previously with the successful biodegradation of nitramine-contaminated soils (Dubois et al. 1997, Greer et al. 1997). At this site the contaminated top layer of soil will be removed and a biopile will be constructed where a bioremediation treatment will be applied. Afterward, a treatment frequency will be established depending on the rate of accumulation of contamination on the soil.

Overall our results, here and in an earlier study (Table 11), demonstrate sampling error generally contributes at least 10 times the uncertainty in results for site characterization than does analytical error. If we hope to improve the quality of the data used to make informed decisions, we must find ways to reduce sampling error. The significant effort that has been made to improve the quality of environmental analyses has centered on improving laboratory performance. Unfortunately, while very well intentioned, this effort is attacking only 10% of the total error. We recommend the use of on-site sample homogenization, compositing of discrete samples, and on-site analysis, with appropriate confirmation of results at an off-site environmental laboratory as a means of addressing the larger problem.

#### LITERATURE CITED

**Burrows, E.P., D.H. Rosenblatt, W.R. Mitchell, and D.L. Parmer** (1989) Organic explosives and related compounds: Environmental and health considerations. USA Biomedical Research and Development Laboratory, Fort Detrick, Maryland, TR-8901.

**Dubois, C., G. Ampleman, S. Thiboutot, C. Greer, J. Hawari, and G. Sunahara** (1997) Bioremediation of RDX-contaminated soil: A preliminary field trial. Presented at the *90th Annual Air & Waste Management Association*, 8–13 June 1997, Toronto, Ontario, Canada.

**EPA** (1995) Nitroaromatics and nitramines by HPLC. Second Update, SW846 Method 8330. U.S. Environmental Protection Agency.

**Grant, C.L., T.F. Jenkins, K.F. Myers, and E.F. McCormick** (1995) Comparison of fortification vs. field contamination for holding time estimates of soils containing explosives residues. *Journal of Environmental Toxicology and Chemistry*, **14**: 1865–1874.

**Greer, C., J. Godbout, B. Zilber, S. Labelle, G. Sunahara, J. Hawari, G. Ampleman, S. Thiboutot, and C. Dubois** (1997) Bioremediation of RDX/HMX-contaminated soil: From flask to field. Presented at the *Fourth International Symposium on In Situ and On-Site Bioremediation*, April 28–May 1, 1997, New Orleans, Louisiana.

**Horowitz, W.** (1982) Evaluation of analytical methods used for regulation of food and drugs. *Analytical Chemistry*, **54**: 67A–76A.

**Jenkins, T.F.** (1990) Development of a simplified field method for the determination of TNT in soil. USA Cold Regions Research and Engineering Laboratory, Special Report 90-38.

**Jenkins, T.F., M.E. Walsh, P.W. Schumacher, and P.G. Thorne** (1995) Development of colorimetric field screening methods for munitions compounds in soil. In *Proceedings of Environmental Monitoring and Hazardous Waste Site Remediation Symposium*, 19–21 June, Munich, Germany.

**Jenkins, T.F., C.L. Grant, G.S. Brar, P.G. Thorne, T.A. Ranney, and P.W. Schumacher** (1996). Assessment of sampling error associated with collection and analysis of soil samples at explosives contaminated sites. USA Cold Regions Research and Engineering Laboratory, Special Report 96-15.

**Jenkins, T.F., and M.E. Walsh** (1992) Development of field screening methods for TNT, 2, 4-DNT, and RDX in soil. *Talanta*, **39**: 419–428.

**McCormick, N.G., J.H. Cornell, and A.M. Kaplan** (1984) The fate of hexahydro-1,3,5-trinitro-1,3,5-triazine (RDX) and related compounds in anaerobic denitrifying continuous culture systems using simulated wastewater. USA Natick Research and Development Laboratory, TR 85/008. ADA 1490462.

**Myers, K.F., E.F. McCormick, A.B. Strong, P.G. Thorne, and T.F. Jenkins** (1994) Comparison of colorimetric and enzyme immunoassay field screening methods for TNT in soil. USA Engineer Waterways Experiment Station, Technical Report IRRP-94-4, Vicksburg, Mississippi.

**Spanggord, R.J., W.R. Mabey, T.W. Chou, S. Lee, and P.L. Alferness** (1983) *Environmental Fate studies of HMX. Phase 2. Detailed Studies*. Menlo Park, California: SRI International. ADA145122.

**Teany, G.B., and R.T. Hudak** (1994) Development of an enzyme immunoassay based field screening system for the detection of RDX in soil and water. In *Proceedings of the 87th Annual Air and Waste Management Association*, paper no. 94-RP 143.05, Cincinnati, Ohio, June 1994.

**Teany, G.B., R.T. Hudak, and J.M. Melby** (1995) On-site soil and water analysis using D-Tech Immunoassay for RDX and TNT. In *Proceedings of Field Screening Methods for Hazardous Wastes and Toxic Chemicals*, Las Vegas, Nevada, 22-24 February 1995, p. 965.

**Thiboutot, S. G. Ampleman, T.F. Jenkins, M.E.**

**Walsh, P.G. Thorne, T.A. Ranney, and C.L. Grant** (in press) Characterization of an antitank firing

range at CFB-Valcartier. DREV report, Defence Research Establishment-Valcartier.

**Thorne, P.G., and D.C. Leggett** (in press). Hydrolytic release of bound residues from composted TNT contaminated soil. *Environmental Toxicology and Chemistry*.

**Walsh, M.E., and Jenkins, T.F.** (1991) Development of a field screening method for RDX in soil. USA Cold Regions Research and Engineering Laboratory, Special Report 91-7.

**Walsh, M.E., T.F. Jenkins, P.S. Schnitker, J.W. Elwell, and M.H. Stutz** (1993) Evaluation of SW846 Method 8330 for characterization of sites contaminated with residues of high explosives. USA Cold Regions Research and Engineering Laboratory, CRREL Report 93-5.

**APPENDIX A: INDIVIDUAL ANALYSES FOR SURFACE SOIL SAMPLES  
OBTAINED IN EACH SUBGRID AND FOR GRID COMPOSITES**

**DATA FOR GRID D1**

HMX Concentration (mg/kg)

GRID NUMBER	Subgrid	Field Sampling Rep.	Analytical Rep.	Lab 8330 AcN	Field Colorimetric	Acetone HPLC	
D1	A		a b mean=	130 230 180	120	111	
	B		a b mean=	57 210 134	121	136	
	C		a b mean=	45 40 43	32	53	
	D		a b mean=	48 120 84	59	77	
	Comp.		a b mean=	96 76 86	71 89 80	82 97 90	
	<b>Means</b>						
		ABCD - a ABCD - b ABCD Comp.			70 150 110 86	83 80	94

2-Am-DNT and 4-Am-DNT Concentration (µg/g)

GRID NUMBER	Subgrid	Field Sampling Rep.	Analytical Rep.	Lab 8330 AcN	Acetone HPLC 4-Am-DNT	Acetone HPLC 2-Am-DNT
D1	A		a b mean=	1.4 1.0 1.2	0.35	0.32
	B		a b mean=	0.9 1.4 1.2	0.33	0.38
	C		a b mean=	0.5 0.6 0.55	0.20	0.23
	D		a b mean=	<0.3 <0.3 <0.3	<d	0.13
	Comp.		a b mean=	0.9 0.9 0.90	0.17 0.27 0.22	0.24 0.26 0.25
	<b>Means</b>					

TNT Concentration (mg/kg)

GRID NUMBER	Subgrid	Field Sampling Rep.	Analytical Rep.	Lab 8330 AcN	Field Colorimetric	Acetone HPLC	DTech
D1	A		a b mean=	<0.3 <0.3 <0.3	<d	<d	0.5 to 1.5
	B		a b mean=	0.3 0.8 0.6	<d	<d	0.5 to 1.5
	C		a b mean=	0.3 0.4 0.4	<d	<d	<0.5
	D		a b mean=	<0.3 0.3 <0.3	<d	0.79	<0.5
	Comp.		a b mean=	0.3 <0.3 <0.3	<d <d	<d <d	<0.5 0.5 to 1.5

RDX Concentration (mg/kg)

GRID NUMBER	Subgrid	Field Sampling Rep.	Analytical Rep.	Lab 8330 AcN	Acetone HPLC
D1	A		a b mean=	<1.0 <1.0 <1.0	0.28
	B		a b mean=	<1.0 <1.0 <1.0	<d
	C		a b mean=	<1.0 <1.0 <1.0	<d
	D		a b mean=	<1.0 <1.0 <1.0	<d
	Comp.		a b mean=	<1.0 <1.0 <1.0	<d 0.28

Other Nitroaromatics Concentration (mg/kg)

GRID NUMBER	Subgrid	Field Sampling Rep.	Analytical Rep.	Lab 8330 AcN TNB and DNB	Acetone HPLC	Lab 8330 AcN 2,4- and 2,6-DNT
D1	A		a b mean=	<0.3 <0.3 <0.3	trace	10 0.3
	B		a b mean=	<0.3 <0.3 <0.3	<d	0.6 0.3
	C		a b mean=	<0.3 <0.3 <0.3	<d	<0.3 <0.3
	D		a b mean=	<0.3 <0.3 <0.3	<d	0.8 <0.3
	Comp.		a b mean=	<0.3 <0.3 <0.3	<d <d	<0.3 0.3

**DATA FOR GRID C10**  
Results from Method 8330

TANK	GRID NUMBER	FIELD dupl.	LAB. dupl.	[HMX] ppm	[RDX] ppm	[TNT] ppm	[2 + 4 Am DNT] ppm	[TNB + DNB] ppm
C	10	A	a	17	<1.0	<0.3	0.5	<0.3
C	10	A	b	13	<1.0	<0.3	0.4	<0.3
C	10	B	a	33	<1.0	<0.3	0.8	<0.3
C	10	B	b	44	<1.0	<0.3	0.8	<0.3
C	10	C	a	1	<1.0	<0.3	<0.3	<0.3
C	10	C	b	2.4	<1.0	<0.3	<0.3	<0.3
C	10	D	a	1.3	<1.0	<0.3	<0.3	<0.3
C	10	D	b	2.3	<1.0	<0.3	<0.3	<0.3
C	10	Comp.	a	12	<1.0	<0.3	<0.3	<0.3
C	10	Comp.	b	14	<1.0	<0.3	0.3	<0.3
<b>NEAN</b>								
C	10	A	mean lab.	15	<1.0	<0.3	0.5	<0.3
C	10	B	mean lab.	39	<1.0	<0.3	0.8	<0.3
C	10	C	mean lab.	2	<1.0	<0.3	<0.3	<0.3
C	10	D	mean lab.	1.8	<1.0	<0.3	<0.3	<0.3
C	10	Comp.	mean lab.	13	<1.0	<0.3	<0.3	<0.3

**DATA FOR GRID C9**  
Results from Method 8330

TANK	GRID NUMBER	FIELD dupl.	LAB. dupl.	[HMX] ppm	[RDX] ppm	[TNT] ppm	[2 + 4 Am DNT] ppm	[TNB + DNB] ppm
C	9	A	a	<1.0	<1.0	<0.3	<0.3	<0.3
C	9	A	b	<1.0	<1.0	<0.3	2.3	<0.3
C	9	B	a	3.8	<1.0	<0.3	<0.3	<0.3
C	9	B	b	3.7	<1.0	<0.3	<0.3	<0.3
C	9	C	a	1.4	<1.0	<0.3	<0.3	<0.3
C	9	C	b	1.7	<1.0	<0.3	<0.3	<0.3
C	9	D	a	1.5	<1.0	<0.3	<0.3	<0.3
C	9	D	b	1.3	<1.0	<0.3	<0.3	<0.3
C	9	Comp.	a	3.6	<1.0	<0.3	<0.3	<0.3
C	9	Comp.	b	4	<1.0	<0.3	<0.3	<0.3
<b>NEAN</b>								
C	9	A	mean lab.	<1.0	<1.0	<0.3	2.3	<0.3
C	9	B	mean lab.	3.8	<1.0	<0.3	<0.3	<0.3
C	9	C	mean lab.	1.6	<1.0	<0.3	<0.3	<0.3
C	9	D	mean lab.	1.4	<1.0	<0.3	<0.3	<0.3
C	9	Comp.	mean lab.	4	<1.0	<0.3	<0.3	<0.3

**DATA FOR GRID C7**  
Results from Method 8330

TANK	GRID NUMBER	FIELD dupl.	LAB. dupl.	[HMX] ppm	[RDX] ppm	[TNT] ppm	[2 + 4 Am DNT] ppm	[TNB + DNB] ppm
C	7	A	a	360	<1.0	10	1.1	<0.3
C	7	A	b	340	<1.0	9.2	1	<0.3
C	7	B	a	530	<1.0	4.6	3.1	<0.3
C	7	B	b	470	<1.0	1.3	2.8	<0.3
C	7	C	a	270	<1.0	<0.3	1	<0.3
C	7	C	b	260	<1.0	<0.3	1.4	<0.3
C	7	D	a	470	<1.0	15	<0.3	<0.3
C	7	D	b	510	<1.0	17	1.9	<0.3
C	7	Comp.	a	370	<1.0	2	1.5	<0.3
C	7	Comp.	b	390	<1.0	8.7	<0.3	<0.3
<b>NEAN</b>								
C	7	A	mean lab.	350	<1.0	10	1	<0.3
C	7	B	mean lab.	500	<1.0	3.0	3.0	<0.3
C	7	C	mean lab.	265	<1.0	<0.3	1	<0.3
C	7	D	mean lab.	490	<1.0	16	1.9	<0.3
C	7	Comp.	mean lab.	380	<1.0	5	1.5	<0.3

**DATA FOR GRID C8**  
Results from Method 8330

TANK	GRID NUMBER	FIELD dupl.	LAB. dupl.	[HMX] ppm	[RDX] ppm	[TNT] ppm	[2 + 4 Am DNT] ppm	[TNB + DNB] ppm
C	8	A	a	66	<1.0	4.8	0.8	<0.3
C	8	A	b	64	<1.0	1.9	0.9	<0.3
C	8	B	a	150	<1.0	0.8	0.9	<0.3
C	8	B	b	110	<1.0	<0.3	1	<0.3
C	8	C	a	38	<1.0	<0.3	<0.3	<0.3
C	8	C	b	13	<1.0	<0.3	<0.3	<0.3
C	8	D	a	5.2	<1.0	<0.3	<0.3	<0.3
C	8	D	b	8.9	<1.0	<0.3	<0.3	<0.3
C	8	Comp.	a	78	<1.0	<0.3	0.6	<0.3
C	8	Comp.	b	54	<1.0	<0.3	0.7	<0.3
<b>MEAN</b>								
C	8	A	mean lab.	65	<1.0	3.4	0.9	<0.3
C	8	B	mean lab.	130	<1.0	0.8	1	<0.3
C	8	C	mean lab.	26	<1.0	<0.3	<0.3	<0.3
C	8	D	mean lab.	7.1	<1.0	<0.3	<0.3	<0.3
C	8	Comp.	mean lab.	66	<1.0	<0.3	0.7	<0.3

**DATA FOR GRID D5**

HMX Concentration (µg/g)

GRID NUMBER	Subgrid	Field Sampling Rep.	Analytical Rep.	Lab 8330 AcN	Field Colorimetric	Acetone HPLC
D5	A		a	120	47	55.9
			b	67	60	68.7
			mean=	94	53	62
	B		a	20	50	19.8
			b	17	17	17.7
			mean=	19	33	19
	C		a	28	8.0	11.6
			b	28	164	10.6
			mean=	28	86	11
	D		a	15	67	76
			b	8.7	40	47
			mean=	12	54	62
	ABCD Comp		a	54	62	40.9
			b	8.7	19	22.0
mean=			31	41	31	
<b>Means</b>						
ABCD - a				46	43	41
ABCD - b				30	70	36
ABCD				38	57	38
<b>Depth Samples</b>						
D (2 to 4")			a	5.9	7.1	6.37
			b	7.1		
			mean=	6.5		
D (4 to 6")			a	1.4	2.5	0.72
			b	1.3		
			mean=	1.4		

TNT Concentration (µg/g)

GRID NUMBER	Subgrid	Field Sampling Rep.	Analytical Rep.	Lab 8330 AcN	Field Colorimetric	Acetone HPLC	DTech	
D5	A		a b mean=	<0.3 <0.3	<d <d	0.27 <d	<0.5 <0.5	
	B		a b mean=	<0.3 <0.3	<d <d	<d <d	<0.5 <0.5	
	C		a b mean=	<0.3 <0.3	1.0 <d	<d <d	<0.5 <0.5	
	D		a b mean=	<0.3 <0.3	<d <d	<d <d	<0.5 <0.5	
	ABCD Comp		a b mean=	<0.3 <0.3	2.7 0.7 1.7	1.91 <d	0.5 to 1.5 <0.5	
	<b>Means</b>							
	ABCD - a ABCD - b ABCD							
	Depth Samples D (2 to 4")			a b mean=	<0.3 <0.3	<d	<d	<0.5
	D (4 to 6")			a b mean=	<0.3 <0.3	<d	<d	<0.5

RDX Concentration (µg/g)

GRID NUMBER	Subgrid	Field Sampling Rep.	Analytical Rep.	Lab 8330 AcN	Acetone HPLC	
D5	A		a b mean=	<1.0 <1.0	<d <d	
	B		a b mean=	<1.0 <1.0	<d <d	
	C		a b mean=	<1.0 <1.0	<d 0.93	
	D		a b mean=	<1.0 <1.0	<d <d	
	ABCD Comp		a b mean=	<1.0 <1.0	0.24 <d	
	Depth Samples D (2 to 4")			a b mean=	<1.0 <1.0	<d
	D (4 to 6")			a b mean=	<1.0 <1.0	<d

2-Am-DNT and 4-Am-DNT Concentration (µg/g)

GRID NUMBER	Subgrid	Field Sampling Rep.	Analytical Rep.	Lab 8330 AcN	Acetone HPLC 4-Am-DNT	Acetone HPLC 2-Am-DNT	
D5	A		a b mean=	0.9 0.5 0.7	<d <d	0.22 0.21 0.22	
	B		a b mean=	<0.3 <0.3	<d <d	0.20 0.13 0.17	
	C		a b mean=	<0.3 <0.3	<d <d	<d 0.10	
	D		a b mean=	<0.3 <0.3	<d <d	<d 0.22	
	ABCD Comp		a b mean=	0.6 <0.3	<d <d	0.16 0.18 0.17	
	Depth Samples D (2 to 4")			a b mean=	0.4 0.5 0.5	<d	<d
	D (4 to 6")			a b mean=	<0.3 <0.3	<d	<d

Other Nitroaromatics Concentration (µg/g)

GRID NUMBER	Subgrid	Field Sampling Rep.	Analytical Rep.	Lab 8330 AcN TNB and DNB	Acetone HPLC	Lab 8330 AcN 2,4- and 2,6-DNT	
D5	A		a b mean=	<0.3 <0.3	<d <d	<0.3 <0.3	
	B		a b mean=	<0.3 <0.3	<d <d	<0.3 <0.3	
	C		a b mean=	<0.3 <0.3	<d <d	<0.3 <0.3	
	D		a b mean=	<0.3 <0.3	<d <d	<0.3 <0.3	
	ABCD Comp		a b mean=	<0.3 <0.3	trace <d	<0.3 <0.3	
	Depth Samples D (2 to 4")			a b mean=	<0.3 <0.3	<d	<0.3 <0.3
	D (4 to 6")			a b mean=	<0.3 <0.3	<d	<0.3 <0.3

**DATA FOR GRID D8**

HMX Concentration (µg/g)

GRID NUMBER	Subgrid	Field Sampling Rep.	Analytical REP	Lab 8330 AcN	Field Colorimetric	Acetone HPLC	
D8	A		a b mean=	750 850 800	878	838	
	B		a b mean=	260 440 350	286	258	
	C		a b mean=	120 150 135	202	187	
	D		a b mean=	140 190 165	208	175	
	Comp.		a b mean=	370 350 360	325 319 322	310 366 338	
	<b>Means</b>						
		ABCD - a			318	394	364
		ABCD - b			408		
		ABCD			363		
		Comp.			360	322	338
	<b>Depth Samples B (2 to 4")</b>						
				a b mean=	520 540 530	560	477
<b>B (4 to 6")</b>							
			a b mean=	570 360 465	1083	990	

RDX Concentration (µg/g)

GRID NUMBER	Subgrid	Field Sampling Rep.	Analytical REP	Lab 8330 AcN	Acetone HPLC	
D8	A		a b mean=	<1.0 <1.0	<d	
	B		a b mean=	<1.0 <1.0	<d	
	C		a b mean=	<1.0 <1.0	<d	
	D		a b mean=	<1.0 <1.0	0.22	
	Comp.		a b mean=	<1.0 <1.0	<d 0.14	
	<b>Depth Samples B (2 to 4")</b>					
				a b mean=	<1.0 <1.0	0.51
	<b>B (4 to 6")</b>					
			a b mean=	<1.0 <1.0	1.24	

TNT Concentration (µg/g)

GRID NUMBER	Subgrid	Field Sampling Rep.	Analytical REP	Lab 8330 AcN	Field Colorimetric	Acetone HPLC	DTech	
D8	A		a b mean=	24 18 21	21	17	16 to 20	
	B		a b mean=	1.2 0.9 1.1	1.5	0.71	1.5 to 3	
	C		a b mean=	1.3 1.7 1.5	1.8	1.11	1.5 to 3	
	D		a b mean=	<0.3 <0.3	1.9	1.16	1.5 to 3	
	Comp.		a b mean=	5.6 9.7 7.7	6.2 3.4 4.8	4.1 2.2 3.1	4 to 5 4 to 5	
	<b>Means</b>							
		ABCD - a				6.6	5.0	
		ABCD - b						
		ABCD						
	<b>Depth Samples B (2 to 4")</b>							
				a b mean=	1.5 1.8 1.7	1.7	1.11	0.5 to 1.5
	<b>B (4 to 6")</b>							
			a <sup>†</sup> b mean=	1.8 1.3 1.55	199	190	>5	

<sup>†</sup>High TNT concentration in acetone extract confirmed by GC-ECD



2-Am-DNT and 4-Am-DNT Concentration (µg/g)

GRID NUMBER	Subgrid	Field Sampling Rep.	Analytical Rep.	Lab 8330 AcN	Acetone HPLC 4-Am-DNT	Acetone HPLC 2-Am-DNT	
D8	A		a b mean=	5.6 4.9 5.3	3.63	1.97	
	B		a b mean=	2.2 2.6 2.4	0.73	0.67	
	C		a b mean=	1.3 1.3 1.3	0.56	0.50	
	D		a b mean=	0.9 0.9 0.9	0.45	0.43	
	Comp.		a b mean=	2.4 2.5 2.5	0.84 0.95 0.89	0.80 0.88 0.84	
	<b>Means</b>						
	ABCD - a			2.5	1.3	0.89	
	ABCD - b			2.4			
	ABCD			2.5			
	Depth Samples B (2 to 4")		a b mean=	2.7 2.4	1.20	1.09	
B (4 to 6")		a <sup>†</sup> b mean=	6.3 5.7	3.69	3.34		

<sup>†</sup>Presence of amino-DNTs in acetone extract confirmed by GC-ECD.

Other Nitroaromatics Concentration (µg/g)

GRID NUMBER	Subgrid	Field Sampling Rep.	Analytical Rep.	Lab 8330 AcN TNB and DNB	Acetone HPLC	Lab 8330 AcN 2,4- and 2,6-DNT
D8	A		a b mean=	<0.3 <0.3	<d	3.1 <0.3
	B		a b mean=	<0.3 <0.3	<d	0.7 <0.3
	C		a b mean=	<0.3 <0.3	<d	<0.3 <0.3
	D		a b mean=	<0.3 <0.3	<d	<0.3 3.8
	Comp.		a b mean=	<0.3 <0.3	<d trace	<0.3 <0.3
	<b>Means</b>					
	Depth Samples B (2 to 4")		a b <sup>†</sup> mean=	<0.3 <0.3	<d	1.8 11 6.4
	B (4 to 6")		a <sup>††</sup> b mean=	<0.3 <0.3	<d	0.3 0.3 0.3

<sup>†</sup>1.1 µg/g tetryl reported for Lab Method 8330 AcN.

<sup>††</sup>Presence of DNTs in acetone extract confirmed by GC-ECD.

**DATA FOR GRID D11**  
Results from Method 8330

TANK	GRID NUMBER	FIELD dupl.	LAB. dupl.	[HMX] ppm	[RDX] ppm	[TNT] ppm	[2 + 4 Am DNT] ppm	[TNB + DNB] ppm
D	11	A	a	1.1	<1.0	<0.3	<0.3	<0.3
D	11	A	b	1.9	<1.0	<0.3	<0.3	<0.3
D	11	B	a	1.2	<1.0	<0.3	<0.3	<0.3
D	11	B	b	6	<1.0	<0.3	<0.3	<0.3
D	11	C	a	<1.0	<1.0	<0.3	<0.3	<0.3
D	11	C	b	8.8	<1.0	<0.3	<0.3	<0.3
D	11	D	a	<1.0	<1.0	<0.3	<0.3	<0.3
D	11	D	b	3.2	<1.0	<0.3	<0.3	<0.3
D	11	Comp.	a	<1.0	<1.0	<0.3	<0.3	<0.3
D	11	Comp.	b	7.9	<1.0	<0.3	<0.3	<0.3
<b>MEAN</b>								
D	11	A	mean lab.	1.5	<1.0	<0.3	<0.3	<0.3
D	11	B	mean lab.	4	<1.0	<0.3	<0.3	<0.3
D	11	C	mean lab.	8.8	<1.0	<0.3	<0.3	<0.3
D	11	D	mean lab.	3.2	<1.0	<0.3	<0.3	<0.3
D	11	Comp.	mean lab.	7.9	<1.0	<0.3	<0.3	<0.3

**DATA FOR GRID D2B**

HMX Concentration (µg/g)

GRID NUMBER	Subgrid	Field Sampling Rep.	Analytical REP	Lab 8330 AcN	Field Colorimetric	Acetone HPLC
D2 (Wheel)	B	1	a	220	101	112
			b	120	99	109
			mean	170	100	111
		2	a	17	20	18
			b	6.7	11	13
			mean	12	16	16
		3	a	320	198	191
			b	250	168	189
			mean	285	183	190
		4	a	150	115	144
			b	120	107	139
			mean	135	111	142
		5	a	290	313	318
			b	310	329	337
			mean	300	321	327
		6	a	390	329	332
			b	420	319	317
			mean	405	324	324
		7	a	110	46	69
			b	54	62	82
			mean	82	54	75
Comp.	a	240	161	182		
	b	120	182	180		
	c		185	190		
		mean	180	176	184	
<b>Means</b>						
		1 - 7 a		214	160	169
		1 - 7 b		183	156	169
		1 - 7		198	158	169

TNT Concentration (µg/g)

GRID NUMBER	Subgrid	Field Sampling Rep.	Analytical REP	Lab 8330 AcN	Field Colorimetric	Acetone HPLC
D2 (Wheel)	B	1	a	<0.3	<d	<d
			b	<0.3	1.1	<d
			mean			
		2	a	<0.3	<d	<d
			b	<0.3	<d	<d
			mean			
		3	a	0.3	<d	<d
			b	<0.3	<d	<d
			mean	0.3		
		4	a	0.4	<d	<d
			b	0.8	1.3	<d
			mean	0.6		
		5	a	1.1	2.0	1.89
b <sup>†</sup>	0.3		2.6	2,4-DNT interference		
mean	0.7		2.3			
6	a	1.3	5.3	4.82		
	b	2.0	3.3	<d		
	mean	1.7	4.3			
7	a	2.7	<d	0.19		
	b	1.2	<d	0.20		
	mean	2.0	<d	0.20		
Comp.	a	<0.3	<d	<d		
	b	<0.3	<d	<d		
	c mean		1.1	0.71		

<sup>†</sup>TNT in acetone extract confirmed by GC-ECD. Found concentrations was 2.8 µg/g.

2-Am-DNT and 4-Am-DNT Concentration (µg/g)

GRID NUMBER	Subgrid	Field Sampling Rep.	Analytical Rep.	Lab 8330 AcN	Acetone HPLC 4-Am-DNT	Acetone HPLC 2-Am-DNT
D2 (Wheel)	B	1	a	2.2	0.36	0.42
			b	1.4	0.37	0.41
			mean	1.8	0.37	0.42
		2	a	0.5	0.20	0.21
			b	0.3	0.13	0.15
			mean	0.4	0.17	0.18
		3	a	2.1	0.49	0.63
			b	1.7	0.53	0.53
			mean	1.9	0.51	0.58
		4	a	3	0.81	0.98
			b	2.6	0.74	0.90
			mean	2.8	0.77	0.94
		5	a	3.4	0.94	0.89
b <sup>†</sup>	2.2		1.19	0.95		
mean	2.8		1.07	0.92		
6	a	3	1.13	1.16		
	b	3.8	1.37	1.40		
	mean	3.4	1.25	1.28		
7	a	<0.3	0.64	0.77		
	b	<0.3	0.60	0.72		
	mean	<0.3	0.62	0.75		
Comp.	a	1.9	0.76	0.82		
	b	1.9	0.72	0.76		
	c mean		0.67	0.73		
Means						
1 - 7 a <sup>††</sup>				2.1	0.65	0.72
1 - 7 b <sup>††</sup>				1.8	0.70	0.72
1 - 7 <sup>††</sup>				1.9	0.68	0.72

<sup>†</sup>Presence of amino-DNTs in acetone extract confirmed by GC-ECD.

<sup>††</sup>Substituted 0.3 for <0.3 in computation of mean for Lab 8330 AcN.

RDX Concentration (µg/g)

GRID NUMBER	Subgrid	Field Sampling Rep.	Analytical REP	Lab 8330 AcN	Acetone HPLC
D2 (Wheel)	B	1	a	<1.0	<d
			b	<1.0	0.13
			mean		
		2	a	<1.0	0.21
			b	<1.0	<d
			mean		
		3	a	<1.0	0.34
			b	<1.0	<d
			mean		
		4	a	<1.0	<d
			b	<1.0	<d
			mean		
		5	a	<1.0	1.39
b <sup>†</sup>	<1.0		1.27		
mean			1.33		
6	a	<1.0	0.26		
	b	<1.0	0.50		
	mean		0.38		
7	a	<1.0	<d		
	b	<1.0	<d		
	mean				
Comp.	a	<1.0	0.13		
	b	<1.0	<d		
	c mean		<d		

<sup>†</sup>Presence of RDX in acetone extract confirmed by GC-ECD.

Other Nitroaromatics Concentration (µg/g)

GRID NUMBER	Subgrid	Field Sampling Rep.	Analytical Rep.	Lab 8330 AcN TNB and DNB	Acetone HPLC	Lab 8330 AcN 2,4- and 2,6-DNT
D2 (Wheel)	B	1	a	<0.3	<d	<0.3
			b	<0.3	<d	<0.3
			mean			
		2	a	<0.3	<d	<0.3
			b	<0.3	<d	<0.3
			mean			
		3	a	<0.3	trace	<0.3
			b	<0.3	<d	0.8
			mean			
		4	a	<0.3	<d	4.2
			b	<0.3	<d	<0.3
			mean			
		5	a	<0.3	<d	26
b <sup>†</sup>	<0.3		<d	6.2		
mean						
6	a	<0.3	<d	39		
	b	<0.3	<d	23		
	mean					
7	a	<0.3	<d	0.5		
	b	<0.3	<d	<0.3		
	mean					
Comp.	a	<0.3	trace	0.9		
	b	<0.3	<d	1.4		
	c mean		<d			

<sup>†</sup>DNTs in acetone extract confirmed by GC-ECD. Found concentrations of 2,4-DNT was 18 µg/g.

**DATA FOR GRID C5**

HMX Concentration (µg/g)

GRID NUMBER	Subgrid	Field Sampling Rep.	Analytical Rep.	Lab 8330 AcN	Field Colorimetric	Acetone HPLC	
C5	A		a	560	461	381	
			b	530			
			mean=	545			
	B			a	98	79	108
				b	130		
				mean=	114		
	C			a	78	129	144
b				150			
mean=				114			
D			a	540	301	284	
			b	620			
			mean=	580			
Comp.			a	250	195	208	
			b	520			
			mean=	385			
<b>Means</b>							
	ABCD - a			319	242	229	
	ABCD - b			358			
	ABCD			338			
	Comp.			385	180	194	

2-Am-DNT and 4-Am-DNT Concentration (µg/g)

GRID NUMBER	Subgrid	Field Sampling Rep.	Analytical Rep.	Lab 8330 AcN	Acetone HPLC 4-Am-DNT	Acetone HPLC 2-Am-DNT	
C5	A		a	0.7	<d	0.30	
			b	0.9			
			mean=	0.8			
	B			a <sup>†</sup>	1.3	0.28	0.29
				b	1.2		
				mean=	1.3		
C			a	0.5	0.23	0.21	
			b	1.2			
			mean=	0.9			
D			a <sup>†</sup>	<0.3	<d	0.37	
			b	<0.3			
			mean=				
Comp.			a	1.9	<d	0.23	
			b	1.4			
			mean=	1.7			
						0.23	
						0.23	

<sup>†</sup>Presence of amino-DNTs in acetone extract confirmed by GC-ECD.

TNT Concentration (µg/g)

GRID NUMBER	Subgrid	Field Sampling Rep.	Analytical Rep.	Lab 8330 AcN	Field Colorimetric	Acetone HPLC	DTech	
C5	A		a	0.7	18.8	18.4	12 to 15	
			b	0.9				
			mean=	0.8				
	B			a	8.2	1.4	2,4-DNT interference <sup>†</sup>	1.5 to 3
				b	1.4			
				mean=	4.8			
	C			a	<0.3	<d	<d	0.5 to 1.5
b				0.8				
mean=								
D			a	78	2.6	2,4-DNT interference <sup>†</sup>	3.0 to 4.0	
			b	67				
			mean=	73				
Comp.			a	6.2	4.8	4.3	4.0 to 5.0	
			b	3.5				
			mean=	4.9				
<b>Means</b>								
	ABCD - a			18				
	ABCD - b							
	ABCD							

<sup>†</sup>TNT in acetone extracts confirmed by GC-ECD. Found concentrations were 1.9 and 2.6 µg/g for C5B and C5D, respectively.

RDX Concentration (µg/g)

GRID NUMBER	Subgrid	Field Sampling Rep.	Analytical Rep.	Lab 8330 AcN	Acetone HPLC	
C5	A		a	<1.0	0.31	
			b	<1.0		
			mean=			
	B			a <sup>†</sup>	<1.0	0.20
				b	<1.0	
mean=						
C			a	<1.0	<d	
			b	<1.0		
			mean=			
D			a <sup>†</sup>	<1.0	1.05	
			b	<1.0		
			mean=			
Comp.			a	<1.0	<d	
			b	<1.0		
			mean=			

<sup>†</sup>Presence of RDX in acetone extract confirmed by GC-ECD.

Other Nitroaromatics Concentration (µg/g)

GRID NUMBER	Subgrid	Field Sampling Rep.	Analytical Rep.	Lab 8330 AcN TNB and DNB	Acetone HPLC	Lab 8330 AcN 2,4- and 2,6-DNT	
C5	A		a	<0.3	trace	<0.3	
			b	<0.3			
			mean=				
	B			a <sup>†</sup>	<0.3	<d	0.4
				b	<0.3		
				mean=			
C			a	<0.3	<d	0.6	
			b	<0.3			
			mean=				
D			a <sup>†</sup>	<0.3	<d	<0.3	
			b	<0.3			
			mean=				
Comp.			a	<0.3	<d	2.1	
			b	<0.3			
			mean=				
						1.4	
						1.8	

<sup>†</sup>DNTs in acetone extract confirmed by GC-ECD. Found concentrations of 2,4-DNT; were 4.2 and 17 µg/g for C5B and C5D, respectively.

**DATA FOR GRID C6**  
Results from Method 8330

TANK	GRID NUMBER	FIELD dupl.	LAB. dupl.	[HMX] ppm	[RDX] ppm	[TNT] ppm	[2 + 4 Am DNT] ppm	[TNB + DNB] ppm
C	6	A	a	860	<1.0	3.8	3.7	<0.3
C	6	A	b	920	<1.0	6	4	<0.3
C	6	B	a	830	<1.0	3.8	2.4	<0.3
C	6	B	b	840	<1.0	26	3.3	<0.3
C	6	C	a	850	<1.0	4.4	2.3	<0.3
C	6	C	b	770	<1.0	8	2.1	<0.3
C	6	D	a	940	<1.0	4.7	3.7	<0.3
C	6	D	b	960	<1.0	2.4	3.3	<0.3
C	6	Comp.	a	850	<1.0	12	2.8	<0.3
C	6	Comp.	b	780	<1.0	5.4	2.3	<0.3
<b>MEAN</b>								
C	6	A	mean lab.	890	<1.0	5	4	<0.3
C	6	B	mean lab.	835	<1.0	15	2.9	<0.3
C	6	C	mean lab.	810	<1.0	6	2.2	<0.3
C	6	D	mean lab.	950	<1.0	3.6	3.5	<0.3
C	6	Comp.	mean lab.	815	<1.0	9	2.6	<0.3

**DATA FOR GRID D7**

HMX Concentration (µg/g)

GRID NUMBER	Subgrid	Field Sampling Rep.	Analytical Rep.	Lab 8330 AcN	Field Colorimetric	Acetone HPLC	
D7	A		a	420	209	228	
			b	330			
			mean	375			
	B			a	1000	1001	1064
				b	1000		
				mean	1000		
	C			a	870	729	741
				b	800		
				mean	835		
	CC	1		a	820	649	826
				b	910		
				mean	865		
	CC	2		a	820	845	940
b				950			
mean				885			
D			a	1400	1140	1012	
			b	1100			
			mean	1250			
ABCD Comp.			a	880	844	745	
			b	780			
			mean	830			
<b>Means</b>							
ABCD - a				923	770	761	
ABCD - b				808			
ABCD				865			
C - CC1 - CC2				862	741	836	
CC1 - CC2				875	747	883	

TNT Concentration (µg/g)

GRID NUMBER	Subgrid	Field Sampling Rep.	Analytical Rep.	Lab 8330 AcN	Field Colorimetric	Acetone HPLC	DTech
D7	A		a b mean	0.8 1.1 1.0	<d	1.01	0.5 to 1.5
	B		a b mean	1.6 1.9 1.8	2.0	interference by 2,4-DNT?	1.5 to 3.0
	C		a b mean	1.2 2.1 1.7	1.5	0.85	0.5 to 1.5
	CC	1	a <sup>†</sup> b mean	1.8 0.6 1.2	2.2	0.88	<0.5
	CC	2	a b mean	1.0 1.0 1.0	9.1	7.3	3 to 4
	D		a b mean	12 5.6 8.8	3.6	2.1	3.0 to 4.0
	ABCD Comp.		a b mean	3.7 21 12	2.5 3.3 2.9	1.4 2.1 1.8	1.5 to 3.0 1.5 to 3.0
	<b>Means</b>						
ABCD - a				3.9			
ABCD - b				2.7			
ABCD				3.3			
C - CC1 - CC2				1.3	4.2	3.0	
CC1 - CC2				1.1	5.6	4.1	

<sup>†</sup>TNT in acetone extract confirmed by GC-ECD. Found concentration was 1.7 µg/g.

RDX Concentration (µg/g)

GRID NUMBER	Subgrid	Field Sampling Rep.	Analytical Rep.	Lab 8330 AcN	Acetone HPLC
D7	A		a b mean	<1.0 <1.0	0.17
	B		a b mean	<1.0 <1.0	1.12
	C		a b mean	<1.0 <1.0	2.16
	CC	1	a <sup>†</sup> b mean	<1.0 <1.0	0.91
	CC	2	a b mean	<1.0 <1.0	1.02
	D		a b mean	<1.0 <1.0	0.34
	ABCD Comp.		a b mean	<1.0 <1.0	11.1 0.56

<sup>†</sup>Presence RDX in acetone extract confirmed by GC-ECD.

2-Am-DNT and 4-Am-DNT Concentration (µg/g)

GRID NUMBER	Subgrid	Field Sampling Rep.	Analytical Rep.	Lab 8330 AcN	Acetone HPLC 4-Am-DNT	Acetone HPLC 2-Am-DNT	
D7	A		a b mean	6.0 5.3 5.7	1.73	1.76	
	B		a b mean	12 14 13	4.23	5.88	
	C		a b mean	10 6.9 8.5	2.46	3.04	
	CC	1	a <sup>†</sup> b mean	9.6 9.4 9.5	3.02	3.96	
	CC	2	a b mean	10 7.8 8.9	3.29	4.60	
	D		a b mean	9.9 7.8 8.9	3.68	3.95	
	ABCD Comp.		a b mean	14 10 12	3.30 2.72 3.01	3.75 3.06 3.40	
	<b>Means</b>						
	ABCD - a				9.5	3.02	3.66
	ABCD - b				8.5		
ABCD				9.0			
C - CC1 - CC2				9.0	2.9	3.9	
CC1 - CC2				9.2	3.2	4.3	

<sup>†</sup>Presence of amino-DNTs in acetone extract confirmed by GC-ECD.

Other Nitroaromatics Concentration (µg/g)

GRID NUMBER	Subgrid	Field Sampling Rep.	Analytical Rep.	Lab 8330 AcN TNB and DNB	Acetone HPLC	Lab 8330 AcN 2,4- and 2,6-DNT
D7	A		a b mean	<0.3 <0.3	<d	0.4 0.5 0.5
	B		a b mean	<0.3 <0.3	<d	2.6 8.8 5.7
	C		a b mean	<0.3 <0.3	<d	0.8 0.4 0.6
	CC	1	a <sup>†</sup> b mean	<0.3 <0.3	<d	6.5 0.3 3.4
	CC	2	a b mean	<0.3 <0.3	<d	0.4 1.5 1.0
	D		a b mean	<0.3 <0.3	<d	8.4 <0.3
	ABCD Comp.		a b mean	<0.3 <0.3	<d <d	6.3 7.1 6.7

<sup>†</sup>Presence of DNTs in acetone extract confirmed by GC-ECD.

**DATA FOR GRID D10**

HMX Concentration (µg/g)

GRID NUMBER	Subgrid	Field Sampling Rep.	Analytical Rep.	Lab 8330 AcN	Field Colorimetric	Acetone HPLC	
D10	A		a b mean	6.0 5.6 5.8	25	10.6	
	AA	1	a b mean	15 11 13.0	4.1	6.5	
	AA	2	a b mean	2.2 4.5 3.4	4.1	8.3	
	B		a b mean	5.6 3.1 4.4	5.1	1.1	
	C		a b mean	3.2 <1.0 2.1	2.4	3.4	
	D		a b mean	32 4.1 18.1	6.4	8.7	
	ABCD Comp.		a	1.6	5.0	5.1	
			b mean	3.8 2.7	4.3 4.7	8.6 6.9	
	<b>Means</b>						
	ABCD - a				12	9.8	6.0
	ABCD - b				3.5		
	ABCD				7.6		
	A - AA1 - AA2				7.4	11.1	8.5
AA1 - AA2				8.2	4.1	7.4	

RDX Concentration (µg/g)

GRID NUMBER	Subgrid	Field Sampling Rep.	Analytical Rep.	Lab 8330 AcN	Acetone HPLC	
D10	A		a b mean	<1.0 <1.0	<d	
	AA	1	a b mean	<1.0 <1.0	<d	
	AA	2	a b mean	<1.0 <1.0	<d	
	B		a b mean	<1.0 <1.0	<d	
	C		a b mean	<1.0 <1.0	<d	
	D		a b mean	<1.0 <1.0	<d	
	ABCD Comp.		a		<1.0	<d
			b mean		<1.0	<d

TNT Concentration (µg/g)

GRID NUMBER	Subgrid	Field Sampling Rep.	Analytical Rep.	Lab 8330 AcN	Field Colorimetric	Acetone HPLC	DTech	
D10	A		a b mean	<0.3 <0.3	<d	<d	<0.5	
	AA	1	a b mean	<0.3 <0.3	<d	<d	<0.5	
	AA	2	a b mean	<0.3 <0.3	<d	<d	<0.5	
	B		a b mean	<0.3 <0.3	<d	<d	<0.5	
	C		a b mean	<0.3 <0.3	<d	<d	<0.5	
	D		a b mean	<0.3 <0.3	<d	<d	<0.5	
	ABCD Comp.		a		<0.3	<d	<d	<0.5
			b mean		<0.3	<d	<d	<0.5



2-Am-DNT and 4-Am-DNT Concentration (µg/g)

GRID NUMBER	Subgrid	Field Sampling Rep.	Analytical Rep.	Lab 8330 AcN	Acetone HPLC 4-Am-DNT	Acetone HPLC 2-Am-DNT
D10	A		a b mean	<0.3 <0.3	<d	<d
	AA	1	a b mean	<0.3 <0.3	<d	<d
	AA	2	a b mean	<0.3 <0.3	<d	<d
	B		a b mean	<0.3 <0.3	<d	<d
	C		a b mean	<0.3 <0.3	<d	<d
	D		a b mean	<0.3 <0.3	<d	<d
	ABCD Comp.		a b mean	<0.3 <0.3	<d <d	<d <d

Other Nitroaromatics Concentration (µg/g)

GRID NUMBER	Subgrid	Field Sampling Rep.	Analytical Rep.	Lab 8330 AcN TNB and DNB	Acetone HPLC	Lab 8330 AcN 2,4- and 2,6-DNT
D10	A		a b mean	<0.3 <0.3	<d	<0.3 <0.3
	AA	1	a b mean	<0.3 <0.3	<d	<0.3 <0.3
	AA	2	a b mean	<0.3 <0.3	<d	<0.3 <0.3
	B		a b mean	<0.3 <0.3	<d	<0.3 <0.3
	C		a b mean	<0.3 <0.3	<d	<0.3 <0.3
	D		a b mean	<0.3 <0.3	<d	<0.3 <0.3
	ABCD Comp.		a b mean	<0.3 <0.3	trace <d	<0.3 <0.3

**DATA FOR GRID D4**

HMX Concentration (µg/g)

GRID NUMBER	Subgrid	Field Sampling Rep.	Analytical Rep.	Lab 8330 AcN	Field Colorimetric	Acetone HPLC	
D4	A		a b mean	640 550 595	631	575	
	AA	1	a b mean	380 250 315	341	439	
	AA	2	a b mean	490 420 455	444	451	
	B		a b mean	240 320 280	148	164	
	C		a b mean	110 100 105	254	292	
	D		a b mean	540 610 575	680	609	
	ABCD Comp.		a b mean	500 430 465	606 352 479	357 352 354	
	<b>Means</b>						
	ABCD - a				383	428	410
	ABCD - b				395		
ABCD				389			
A - AA1 - AA2				455	472	488	
AA1 - AA2				385	393	445	

TNT Concentration (µg/g)

GRID NUMBER	Subgrid	Field Sampling Rep.	Analytical Rep.	Lab 8330 AcN	Field Colorimetric	Acetone HPLC	DTech	
D4	A		a b mean	1.7 0.8 1.3	2.1	0.7	0.5 to 1.5	
	AA	1	a b mean	0.4 <0.3	1.5	0.4	1.5 to 3	
	AA	2	a b mean	0.4 0.4 0.4	1.7	1.0	<0.5	
	B		a b mean	0.8 0.6 0.7	<d	<d	<0.5	
	C		a b mean	0.6 <0.3	3.0	1.3	<0.5	
	D		a b mean	0.6 0.6 0.6	1.4	0.7	<0.5	
	ABCD Comp.		a b mean	0.7 0.6 0.65	3.3 3.4 3.4	3.7 2.2 3.0	1.5 to 3.0 0.5 to 1.5	
	<b>Means</b>							
	ABCD - a				0.93	2.2	0.9	
	ABCD - b							
ABCD								
A - AA1 - AA2					1.8	0.7		
AA1 - AA2					1.6	0.7		

RDX Concentration (µg/g)

GRID NUMBER	Subgrid	Field Sampling Rep.	Analytical Rep.	Lab 8330 AcN	Acetone HPLC
D4	A		a b mean	<1.0 <1.0	<d
	AA	1	a b mean	<1.0 <1.0	<d
	AA	2	a <sup>†</sup> b mean	<1.0 <1.0	0.36
	B		a b mean	<1.0 <1.0	0.20
	C		a b mean	<1.0 <1.0	<d
	D		a b mean	<1.0 <1.0	0.16
	ABCD Comp.		a b mean	<1.0 <1.0	1.86 <d

<sup>†</sup>Presence of RDX in acetone extract confirmed by GC-ECD.

Other Nitroaromatics Concentration (µg/g)

GRID NUMBER	Subgrid	Field Sampling Rep.	Analytical Rep.	Lab 8330 AcN TNB and DNB	Acetone HPLC	Lab 8330 AcN 2,4- and 2,6-DNT
D4	A		a b mean	<0.3 <0.3	<d	<0.3 <0.3
	AA	1	a b mean	<0.3 <0.3	<d	<0.3 <0.3
	AA	2	a b mean	<0.3 <0.3	<d	<0.3 <0.3
	B		a b mean	<0.3 <0.3	<d	<0.3 <0.3
	C		a b mean	<0.3 <0.3	<d	<0.3 <0.3
	D		a b mean	<0.3 <0.3	<d	<0.3 <0.3
	ABCD Comp.		a b mean	<0.3 <0.3	trace <d	<0.3 <0.3

2-Am-DNT and 4-Am-DNT Concentration (µg/g)

GRID NUMBER	Subgrid	Field Sampling Rep.	Analytical Rep.	Lab 8330 AcN	Acetone HPLC 4-Am-DNT	Acetone HPLC 2-Am-DNT	
D4	A		a b mean	5.3 8.6 7.0	1.42	1.53	
	AA	1	a b mean	3.0 2.2 2.6	1.09	1.10	
	AA	2	a <sup>†</sup> b mean	3.3 3.2 3.3	0.98	1.03	
	B		a b mean	1.8 1.7 1.8	0.32	0.29	
	C		a b mean	1.2 0.8 1.0	0.77	0.81	
	D		a b mean	4.0 3.4 3.7	1.41	1.32	
	ABCD Comp.		a b mean	2.5 2.3 2.4	1.09 0.98 1.03	1.10 1.03 1.06	
	<b>Means</b>						
	ABCD - a				3.1	0.98	0.99
	ABCD - b				3.6		
ABCD				3.4			
A - AA1 - AA2				4.3	1.2	1.2	
AA1 - AA2				2.9	1.0	1.1	

<sup>†</sup>Presence of amino-DNTs in acetone extracts confirmed by GC-ECD.

**DATA FOR GRID D2**

HMX Concentration (µg/g)

GRID NUMBER	Subgrid	Field Sampling Rep.	Analytical Rep.	Lab 8330 AcN	Field Colorimetric	Acetone HPLC
D2	A		a	470	309	340
			b	420	249	277
			mean	445	279	308
	B		a	430	284	297
			b	480	258	293
			mean	455	271	295
	C		a	350	290	301
			b	410	341	349
			mean	380	316	325
	CC	1	a	230	210	231
	b	260				
		mean	245			
	CC	2	a	270	337	370
			b	290		
mean			280			
D		a	68	37	62	
		b	72	45	77	
		mean	70	41	69	
DD	1	a	120	111	122	
		b	120			
		mean	120			
DD	2	a	150	165	165	
		b	87			
		mean	119			
ABCD Comp.		a	250	226	254	
		b	290	199	206	
		mean	270	212	230	
<b>Means</b>						
ABCD - a				330	230	250
ABCD - b				346	223	249
ABCD				338	227	249
C - CC1 - CC2				302		
CC1 - CC2				263	273	301
D - DD1 - DD2				103		
DD1 - DD2				119	138	144

TNT Concentration (µg/g)

GRID NUMBER	Subgrid	Field Sampling Rep.	Analytical Rep.	Lab 8330 AcN	Field Colorimetric	Acetone HPLC	DTech	
D2	A		a b mean	<0.3 <0.3 <0.3	6.5 <d	5.6 0.3 3.0	3.0 to 4.0 3.0 to 4.0	
	B		a b mean	1.0 0.6 0.8	5.6 1.8 3.7	5.1 1.3 3.2	4.0 to 5.0 1.5 to 3.0	
	C		a b mean	3.8 3.8 3.8	2.2 <d	trace 1.0	<0.5 1.5 to 3.0	
	CC	1	a b mean	1.1 1.2 1.2	3.4	2.8	3 to 4	
	CC	2	a b mean	1.2 5.8 3.5	4.0	2.9	3 to 4	
	D		a b mean	1.1 0.4 0.8	<d <d	trace 0.2	<0.5 <0.5	
	DD	1	a b mean	0.8 0.5 0.7	1.0	0.23	<0.5	
	DD	2	a b mean	1.4 0.8 1.1	1.9	1.5	<0.5	
	ABCD Comp.		a b mean	0.6 0.6 0.6	1.4 0.9 1.2	0.9 0.6 0.8	<0.5 0.5 to 1.5	
	<b>Means</b>							
	ABCD - a							
	ABCD - b							
ABCD								
C - CC1 - CC2								
CC1 - CC2								
D - DD1 - DD2								
DD1 - DD2								

RDX Concentration (µg/g)

GRID NUMBER	Subgrid	Field Sampling Rep.	Analytical Rep.	Lab 8330 AcN	Acetone HPLC
D2	A		a b mean	<1.0 <1.0	<d 0.47
	B		a b mean	<1.0 <1.0	0.49 0.92 0.71
	C		a b mean	<1.0 <1.0	0.24 d
	CC	1	a b mean	<1.0 <1.0	0.22
	CC	2	a b mean	<1.0 <1.0	d
	D		a b mean	<1.0 <1.0	d d
	DD	1	a b mean	<1.0 <1.0	0.11
	DD	2	a b mean	<1.0 <1.0	d
	ABCD Comp.		a b mean	<1.0 <1.0	d 0.17

2-Am-DNT and 4-Am-DNT Concentration (µg/g)

GRID NUMBER	Subgrid	Field Sampling Rep.	Analytical Rep.	Lab 8330 AcN	Acetone HPLC 4-Am-DNT	Acetone HPLC 2-Am-DNT
D2	A		a	1.7	0.67	0.81
			b	2.4	0.73	0.83
			mean	2.1	0.70	0.82
	B		a	2.7	0.83	0.81
			b	2.2	0.78	0.85
			mean	2.5	0.80	0.83
	C		a	3.2	0.97	1.08
			b	3.9	1.06	1.15
			mean	3.6	1.02	1.11
	CC	1	a	1.2	0.33	0.24
			b mean	0.9 1.1		
	CC	2	a	2.7	0.97	1.03
			b mean	3.0 2.9		
	D		a	0.9	0.26	0.28
			b	0.8	0.24	0.31
mean			0.9	0.25	0.30	
DD	1	a	1.1	0.30	0.34	
		b mean	0.9 1.0			
DD	2	a	1.0	0.49	0.44	
		b mean	1.8 1.4			
ABCD Comp.		a	2.1	0.64	0.72	
		b	2.0	0.58	0.67	
		mean		0.61	0.70	
<b>Means</b>						
ABCD - a				2.1	0.68	0.75
ABCD - b				2.3	0.70	0.78
ABCD				2.2	0.69	0.77
C - CC1 - CC2				2.5		
CC1 - CC2				2.0	0.65	0.63
D - DD1 - DD2				1.1		
DD1 - DD2				1.2	0.40	0.39

Other Nitroaromatics Concentration (µg/g)

GRID NUMBER	Subgrid	Field Sampling Rep.	Analytical Rep.	Lab 8330 AcN TNB and DNB	Acetone HPLC	Lab 8330 AcN 2,4- and 2,6-DNT
D2	A		a	<0.3	ΔΔ	0.8
			b	<0.3	ΔΔ	1.6
			mean			
	B		a	<0.3	ΔΔ	<0.3
			b	<0.3	ΔΔ	<0.3
			mean			
	C		a	<0.3	trace	<0.3
			b mean	<0.3		
	CC	1	a	<0.3	Δ	<0.3
			b mean	<0.3		
CC	2	a	<0.3	Δ	13	
		b mean	<0.3			
D		a	<0.3	ΔΔ	6.7	
		b	<0.3	ΔΔ	<0.3	
		mean				
DD	1	a	<0.3	Δ	<0.3	
		b mean	<0.3			
DD	2	a	<0.3	Δ	<0.3	
		b mean	<0.3			
ABCD Comp.		a	<0.3	ΔΔ	<0.3	
		b	<0.3	ΔΔ	24	
		mean				

**DATA FOR GRID D9**

HMX Concentration (µg/g)

GRID NUMBER	Subgrid	Field Sampling Rep.	Analytical Rep.	Lab 8330 AcN	Field Colorimetric	Acetone HPLC	
D9	A		a b mean	14 12 13	10	17.1	
	B		a b mean	89 110 100	180	163	
	BB	1	a b mean	65 81 73	116	128	
	BB	2	a b mean	74 100 87	120	122	
	C		a b mean	460 12 236	20	21	
	CC	1	a b mean	6.4 4.6 5.5	1.4	5.2	
	CC	2	a b mean	7.3 7.4 7.4	51	59	
	D		a b mean	23 12 18	14	20	
	ABCD Comp.		a b mean	35 32 34	45 26 35	47 40 44	
	<b>Means</b>						
	ABCD - a				147	56	55
	ABCD - b				37		
	ABCD				92		
	B - BB1 - BB2				87	139	138
BB1 - BB2				80	118	125	
C - CC1 - CC2				83	24	28	
CC1 - CC2				6.4	26	32	

TNT Concentration (µg/g)

GRID NUMBER	Subgrid	Field Sampling Rep.	Analytical Rep.	Lab 8330 AcN	Field Colorimetric	Acetone HPLC	DTech
D9	A		a b mean	<0.3 <0.3	1.7	0.11	<0.5
	B		a b mean	0.4 <0.3	<d	<d	<0.5
	BB	1	a b mean	<0.3 <0.3	1.2	0.17	<0.5
	BB	2	a b mean	<0.3 <0.3	0.5	0.41	<0.5
	C		a b mean	220 1.6 111	<d	<d	<0.5
	CC	1	a b mean	<0.3 <0.3	<d	0.06	<0.5
	CC	2	a <sup>†</sup> b mean	<0.3 <0.3	17	15	12 to 16
	D		a b mean	<0.3 <0.3	<d	0.26	<0.5
	ABCD Comp.		a b mean	<0.3 1	1.7 1.9 1.8	0.19 <d	<0.5 <0.5

<sup>†</sup>TNT in acetone extract confirmed by GC-ECD. Found concentration was 15µg/g.

RDX Concentration (µg/g)

GRID NUMBER	Subgrid	Field Sampling Rep.	Analytical Rep.	Lab 8330 AcN	Acetone HPLC
D9	A		a b mean	<1.0 <1.0	<d
	B		a b mean	<1.0 <1.0	<d
	BB	1	a b mean	<1.0 <1.0	<d
	BB	2	a b mean	<1.0 <1.0	<d
	C		a b mean	<1.0 <1.0	<d
	CC	1	a b mean	<1.0 <1.0	<d
	CC	2	a b mean	<1.0 <1.0	<d
	D		a b mean	<1.0 <1.0	<d
	ABCD Comp.		a b mean	<1.0 <1.0	5.02 <d

RDX Concentration (µg/g)

GRID NUMBER	Subgrid	Field Sampling Rep.	Analytical Rep.	Lab 8330 AcN	Acetone HPLC
D9	A		a b mean	<1.0 <1.0	<d
	B		a b mean	<1.0 <1.0	<d
	BB	1	a b mean	<1.0 <1.0	<d
	BB	2	a b mean	<1.0 <1.0	<d
	C		a b mean	<1.0 <1.0	<d
	CC	1	a b mean	<1.0 <1.0	<d
	CC	2	a b mean	<1.0 <1.0	<d
	D		a b mean	<1.0 <1.0	<d
	ABCD Comp.		a b mean	<1.0 <1.0	5.02 <d

Other Nitroaromatics Concentration (µg/g)

GRID NUMBER	Subgrid	Field Sampling Rep.	Analytical Rep.	Lab 8330 AcN TNB and DNB	Acetone HPLC	Lab 8330 AcN 2,4- and 2,6-DNT
D9	A		a b mean	<0.3 <0.3	trace	<0.3 <0.3
	B		a b mean	<0.3 <0.3	trace	<0.3 <0.3
	BB	1	a b mean	<0.3 <0.3	trace	<0.3 <0.3
	BB	2	a b mean	<0.3 <0.3	<d	<0.3 <0.3
	C		a b mean	<0.3 <0.3	<d	0.3 <0.3
	CC	1	a b mean	<0.3 <0.3	<d	<0.3 <0.3
	CC	2	a b mean	<0.3 <0.3	<d	<0.3 <0.3
	D		a b mean	<0.3 <0.3	<d	<0.3 <0.3
	ABCD Comp.		a b mean	<0.3 <0.3	<d	<0.3 <0.3



**DATA FOR GRID C4**

HMX Concentration (µg/g)

GRID NUMBER	Subgrid	Field Sampling Rep.	Analytical Rep.	Lab 8330 AcN	Field Colorimetric	Acetone HPLC	
C4	A		a b mean	1200 2000 1600	1915	1849	
	AA	1	a b mean	1400 1500 1450	1172	1240	
	AA	2	a b mean	740 1400 1070	1263	1355	
	B		a b mean	940 1000 970	721	791	
	C		a b mean	960 950 955	995	920	
	CC	1	a b mean	1400 920 1160	984	1056	
	CC	2	a b mean	880 890 885	871	860	
	D		a b mean	1700 2100 1900	2156	2068	
	ABCD Comp.		a b mean	1300 1500 1400	1272 1999 1636	1343	
	<b>Means</b>						
	ABCD - a				1200	1447	1407
	ABCD - b				1513		
	ABCD				1356		
	A - AA1 - AA2				1373	1450	1481
AA1 - AA2				1260	1218	1297	
C - CC1 - CC2				1000	950	945	
CC1 - CC2				1023	928	958	

TNT Concentration (µg/g)

GRID NUMBER	Subgrid	Field Sampling Rep.	Analytical Rep.	Lab 8330 AcN	Field Colorimetric	Acetone HPLC	DTech	
C4	A		a b mean	4.0 11 7.5	13	11	12 to 15	
	AA	1	a b mean	2.0 11 6.5	6.5	5.6	4 to 5	
	AA	2	a b mean	1.3 3.9 2.6	4.8	3.9	4 to 5	
	B		a b mean	10 21 16	5.6	4.3	4 to 5	
	C		a <sup>†</sup> b mean	5.9 3.6 4.8	11	2,4-DNT interference	4.5 to 9	
	CC	1	a <sup>†</sup> b mean	2.7 5.9 4.3	3.0	2.5	4 to 5	
	CC	2	a <sup>†</sup> b mean	4.3 5.0 4.7	1.7	3.4	4 to 5	
	D		a b mean	11 9.7 10	23	20	12 to 15	
	ABCD Comp.		a b mean	4.6 3.1 3.9	19 35 27	16	4.5 to 9 12 to 16	
	<b>Means</b>							
	ABCD - a				7.7	13	12	
	ABCD - b				11			
ABCD				10				
A - AA1 - AA2				5.5	8.0	6.8		
AA1 - AA2				4.6	5.7	4.8		
C - CC1 - CC2				4.6	5.3			
CC1 - CC2				4.5	2.3	2.9		

<sup>†</sup>TNT in acetone extract confirmed by GC-ECD. Found concentrations were 15.9, 3.6 µg/g and 4.1 for C4C, C4CC1 and C4CC2, respectively.

RDX Concentration (µg/g)

GRID NUMBER	Subgrid	Field Sampling Rep.	Analytical Rep.	Lab 8330 AcN	Acetone HPLC
C4	A		a b mean	<1.0 <1.0	1.49
	AA	1	a b mean	<1.0 <1.0	1.68
	AA	2	a b mean	<1.0 <1.0	0.75
	B		a b mean	<1.0 <1.0	1.65
	C		a <sup>†</sup> b mean	<1.0 <1.0	6.26
	CC	1	a <sup>†</sup> b mean	4.5 <1.0	0.52
	CC	2	a <sup>†</sup> b mean	<1.0 <1.0	0.63
	D		a b mean	<1.0 1.3	7.33
	ABCD Comp.		a b mean	1.3 <1.0	1.15
	<b>Means</b>				

<sup>†</sup>Presence of RDX in acetone extracts confirmed by GC-ECD.

2-Am-DNT and 4-Am-DNT Concentration (µg/g)

GRID NUMBER	Subgrid	Field Sampling Rep.	Analytical Rep.	Lab 8330 AcN	Acetone HPLC 4-Am-DNT	Acetone HPLC 2-Am-DNT
C4	A		a	3.2	d	1.36
			b	5.2		
			mean	4.2		
	AA	1	a	2.8	1.04	0.84
			b	3.5		
			mean	3.2		
	AA	2	a	0.4	1.02	0.91
			b	2.1		
			mean	1.3		
	B		a	2.7	d	0.79
			b	7.7		
			mean	5.2		
	C		a <sup>†</sup>	2.5	d	1.01
			b	2.5		
			mean	2.5		
CC	1	a <sup>†</sup>	3.5	1.31	1.07	
		b	2.8			
		mean	3.2			
CC	2	a <sup>†</sup>	2.6	1.34	1.14	
		b	3.1			
		mean	2.9			
D		a	7.3	d	2.37	
		b	7.5			
		mean	7.4			
ABCD Comp.		a	4	1.60	1.19	
		b	4.6			
		mean	4.3			
<b>Means</b>						
ABCD - a				3.9		
ABCD - b				5.7		
ABCD				4.8		
A - AA1 - AA2				2.9		
AA1 - AA2				2.2		
C - CC1 - CC2				2.8		
CC1 - CC2				3.0		

<sup>†</sup>Presence of amino-DNTs in acetone extracts confirmed by GC-ECD.

Other Nitroaromatics Concentration (µg/g)

GRID NUMBER	Subgrid	Field Sampling Rep.	Analytical Rep.	Lab 8330 AcN TNB and DNB	Acetone HPLC	Lab 8330 AcN 2,4- and 2,6-DNT
C4	A		a	<0.3	d	<0.3
			b	<0.3		
			mean			
	AA	1	a	<0.3	d	<0.3
			b	<0.3		
			mean			
	AA	2	a	<0.3	d	<0.3
			b	<0.3		
			mean			
	B		a	<0.3	d	<0.3
b			<0.3			
mean						
C		a <sup>†</sup>	<0.3	d	<0.3	
		b	<0.3			
		mean				
CC	1	a <sup>†</sup>	<0.3	d	<0.3	
		b	<0.3			
		mean				
CC	2	a <sup>†</sup>	<0.3	d	0.5	
		b	<0.3			
		mean	<0.3			
D		a	0.5	d	<0.3	
		b	0.6			
		mean	4.2			
ABCD Comp.		a	<0.3	d	1.8	
		b	<0.3			
		mean	<0.3			

<sup>†</sup>Presence of DNTs in acetone extracts confirmed by GC-ECD.

# REPORT DOCUMENTATION PAGE

Form Approved  
OMB No. 0704-0188

Public reporting burden for this collection of information is estimated to average 1 hour per response, including the time for reviewing instructions, searching existing data sources, gathering and maintaining the data needed, and completing and reviewing the collection of information. Send comments regarding this burden estimate or any other aspect of this collection of information, including suggestion for reducing this burden, to Washington Headquarters Services, Directorate for Information Operations and Reports, 1215 Jefferson Davis Highway, Suite 1204, Arlington, VA 22202-4302, and to the Office of Management and Budget, Paperwork Reduction Project (0704-0188), Washington, DC 20503.

1. AGENCY USE ONLY (Leave blank)		2. REPORT DATE September 1997		3. REPORT TYPE AND DATES COVERED		
4. TITLE AND SUBTITLE Assessment of Sampling Error Associated with Collection and Analysis of Soil Samples at a Firing Range Contaminated with HMX				5. FUNDING NUMBERS		
6. AUTHORS Thomas F. Jenkins, Marianne E. Walsh, Philip G. Thorne, Sonia Thiboutot, Guy Ampleman, Thomas A. Ranney, and Clarence L. Grant						
7. PERFORMING ORGANIZATION NAME(S) AND ADDRESS(ES) U.S. Army Cold Regions Research and Engineering Laboratory 72 Lyme Road Hanover, New Hampshire 03755-1290				8. PERFORMING ORGANIZATION REPORT NUMBER Special Report 97-22		
9. SPONSORING/MONITORING AGENCY NAME(S) AND ADDRESS(ES) U.S. Army Environmental Center     Directorate of Ammunition Programme Aberdeen Proving Ground,             Management Maryland 21010-5401                     Engineering Services Department of National Defence, Canada				10. SPONSORING/MONITORING AGENCY REPORT NUMBER SFIM-AEC-ET-CR-97025		
11. SUPPLEMENTARY NOTES For conversion of SI units to non-SI units of measurement, consult ASTM Standard E380-93, <i>Standard Practice for Use of the International System of Units</i> , published by the American Society for Testing and Materials, 1916 Race St., Philadelphia, Pa. 19103.						
12a. DISTRIBUTION/AVAILABILITY STATEMENT  Approved for public release; distribution is unlimited.  Available from NTIS, Springfield, Virginia 22161				12b. DISTRIBUTION CODE		
13. ABSTRACT ( <i>Maximum 200 words</i> ) Short-range and mid-range (grid size) spatial heterogeneity in explosives concentrations within surface soils was studied at an active antitank firing range at the Canadian Force Base-Valcartier, Val-Bélair, Quebec. The range has been in use for over 20 years. Intensive sampling was conducted over short distances using a 6-m square grid (36-m <sup>2</sup> ) pattern including two target tanks. Sixteen grids were installed. Four area-integrated surface samples were formed into piles, one in each quadrant of each grid, using a circular pattern that included about 10% of the top 5 cm of the quadrant. After in-situ homogenization of a pile, several random aliquots were combined to form a representative sample. Replicates were collected to assess the representativeness achieved. In addition, grid composites were prepared by combining equal portions of the four subgrid samples for each of sixteen grids. In nine of the subgrids, a second area integrated sample was prepared. On-site analysis showed concentrations of HMX ranging from as high as 1640 mg/kg near one target to 2.1 mg/kg at a distance of 15 m from the target. On the other hand, TNT concentrations were much lower than would be expected based on the 70:30 composition ratio of HMX to TNT in the melt-cast explosive used on site. A colorimetric method, originally developed to analyze for RDX, was found to provide concentration estimates for HMX that were in excellent agreement with laboratory results. Spatial heterogeneity of HMX concentrations was large on both short- and mid-range scales and this factor dominated the overall uncertainty associated with site characterization. Relatively minor uncertainties were due to analytical error.						
14. SUBJECT TERMS Analytical error Colorimetric methods				Compositing Explosives Firing range	HMX On-site analysis Sampling error	Soil Spatial heterogeneity TNT
				15. NUMBER OF PAGES 61		
				16. PRICE CODE		
17. SECURITY CLASSIFICATION OF REPORT UNCLASSIFIED		18. SECURITY CLASSIFICATION OF THIS PAGE UNCLASSIFIED		19. SECURITY CLASSIFICATION OF ABSTRACT UNCLASSIFIED		
				20. LIMITATION OF ABSTRACT UL		