

**APPLICATION GUIDE FOR BIOSLURPING
PRINCIPLES AND PRACTICES OF BIOSLURPING
ADDENDUM : USE OF PRE-PUMP SEPARATION FOR IMPROVED
BIOSLURPER SYSTEM OPERATION**

By

Matthew Place, Battelle

Ronald Hoeppe, NFESC

Tanwir Chaudhry, Intergraph Corp.

Sarah McCall, Battelle

Travis Williamson, Battelle

November 2003

*Review of this material does not imply
Department of Defense indorsement or factual accuracy or opinion.*

CONTENTS

FIGURES	ii
TABLES	ii
Section 1.0: INTRODUCTION	1
Section 2.0: PRE-PUMP SEPARATION SYSTEMS	3
2.1 Knockout Tank Separation	3
2.2 In-Well Dual Drop Tube System	3
Section 3.0: DESIGN OF THE PREPUMP SEPARATION SYSTEMS	6
3.1 Design of the Knockout Tank	6
3.2 Design of the Dual Drop Tube	7
Section 4.0: OPERATION AND MAINTENANCE OF PREPUMP SEPARATION SYSTEM	10
4.1 Operation and Maintenance of the Knockout Tank	10
4.2 Operation and Maintenance of the Dual Drop Tube	11
4.3 Troubleshooting of the Prepump Separation Systems	12
Section 5.0: COST ASSESSMENT	13
Section 6.0: REFERENCES	18

FIGURES

Figure 1. Schematic of a Typical Knockout Tank System	4
Figure 2. Dual Drop Tube Design (not to scale)	5
Figure 3. Dual Drop Tube Assembly	5
Figure 4. Engineering Specifics for the Knockout Tank	7
Figure 5. Engineering Design of the Dual Drop Tube System	9

TABLES

Table 1. Estimated Full-Scale Implementation Costs for Conducting In-Well Separation Bioslurping	15
Table 2. Estimated Full-Scale Implementation Costs for Conducting Bioslurping with Manual Removal of Floating Solids	16
Table 3. Estimated Full-Scale Implementation Costs for Conducting Bioslurping with DAF Unit for Postpump Treatment	17

Section 1.0: INTRODUCTION

The purpose of the document is to provide remedial project managers and operators of multi-phase extraction systems the ability to design and operate prepump separation systems to improve the operation of their recovery systems. Prepump separation systems remove the light non-aqueous phase liquid (LNAPL) from the process stream before the stream enters the extraction pump, thus eliminating the mixing of the LNAPL, groundwater, and air as the process stream moves through the pump. Information regarding the use of prepump separation systems was produced during demonstrations of the technologies funded by the Environmental Security Technology Certification Program (ESTCP). Two types of prepump separation systems were tested during the demonstrations. The dual drop tube system removes the LNAPL from the process stream inside the extraction well and the knockout tank removes the LNAPL from the stream just before it enters the extraction pump. This user's guide was produced as an addendum to the Navy's Application Guide. As such, the majority of background information on general bioslurping can be found in the Application Guide.

Bioslurping is a demonstrated technology for cost-effectively removing LNAPL from contaminated aquifers. Bioslurping combines vacuum-assisted LNAPL recovery with bioventing and soil vapor extraction (SVE) to simultaneously recover LNAPL from the water table and accentuate bioremediation of the vadose zone by promoting the influx of air. A conventional bioslurper system withdraws groundwater, soil gas, and free-phase LNAPL from the water table as a single process stream, through a single vacuum drop tube situated in each extraction well, most often using the vacuum created by an aboveground liquid ring pump. The recovered LNAPL is separated from the groundwater and soil vapor and may be recycled. The recovered groundwater and soil vapor usually are treated and discharged. Because bioslurping can greatly enhance LNAPL recovery in comparison to conventional skimming and pump-drawdown technologies (Place et al., 2001; Hoeppe et al., 1998; Wickramanayake et al., 1996), bioslurping potentially can save the U.S. Department of Defense (DoD) significant funds by reducing the amount of time required to remediate LNAPL-contaminated sites.

The greatest drawback to the operation of the conventional bioslurper is the production of frothy floating solids and suspended emulsions caused by the mixing of the fuel, groundwater, and soil gas during the extraction process. The use of oil/water separators located in front of the extraction pump prevents most of the component mixing and reduces the production of the emulsions and floating solids. The use of the prepump separation systems also reduces the petroleum hydrocarbon concentrations in the off gas.

Demonstrations of the prepump separation systems were conducted at six sites, which had different geologic conditions, contaminant levels (LNAPL thickness), and LNAPL types. The results from the demonstrations indicate that the dual-drop tube configuration did not affect the recovery of the LNAPL relative to operation in the conventional configuration. In general, the LNAPL recovery rates decreased throughout the demonstration, but did not significantly decrease when operating in the dual-drop tube configuration. The in-well separation configuration enhanced the bioslurper system performance. In addition, the dual-drop tube configuration did not appear to alter the groundwater recovery rate. There was a 98-99% reduction in the total petroleum hydrocarbons (TPH) in the pump effluent water at all of the sites. There was an average reduction in the TPH in the off-gas of approximately 33%. Also, there was near complete elimination of the floating solids and emulsion in the pump effluent water. The in-well separation technology works at a variety of sites that include tidal influence, varied geologic conditions, and varied LNAPL types and thickness. The in-well separation technology also provides a considerable cost savings when compared to the conventional configuration.

Section 2.0: PRE-PUMP SEPARATION SYSTEMS

2.1 Knockout Tank Separation

A schematic of a bioslurper system equipped with a pre-pump knockout tank is shown in Figure 1. The aboveground knockout tank, which consists of a vacuum resistant tank located on the influent side of the liquid ring pump (LRP in the figure), can treat the liquid stream coming from all of the extraction wells connected to the bioslurper. It serves to separate groundwater and soil gas from the LNAPL prior to liquid mixing within the vacuum pump. The piping system coming from the tank, as shown in Figure 1, controls the separation process. The upper section of the piping leaving the tank removes soil gas, while the lower section removes groundwater. The liquid level in the tank is kept constant by removing soil gas and groundwater at the same rate at which they enter the tank. This is controlled by the proper placement of the tank influent and effluent piping. The influent pipe coming from the vacuum manifold system and wells must be located above the static fluid level in the tank, which is determined by the location of the tee fitting on the effluent (pump) side of the tank. The LNAPL floating on the surface of the water within the tank gravity-drains automatically to a fuel storage tank when it reaches a preset level. The fuel storage tank is kept under vacuum to allow the LNAPL to drain properly.

2.2 In-Well Dual Drop Tube System

As mentioned previously, floating solids and emulsions may form in the vacuum manifold before they are subject to the mixing in the liquid ring pump. The potential for the production of these solids and emulsions should be significantly reduced if LNAPL and groundwater can be separated in the well prior to vacuum extraction. The in-well dual drop tube system provides an effective means to achieve this goal. A schematic diagram of the dual drop tube system for in-well separation is displayed in Figure 2. A single aboveground vacuum pump is used to enhance the subsurface migration of LNAPL to the extraction well, which is similar to the conventional single drop tube design. However, with the dual drop tube design, LNAPL and groundwater are extracted from the well in separate streams through two separate drop tubes. The larger of the two drop tubes is called the “primary drop tube.”

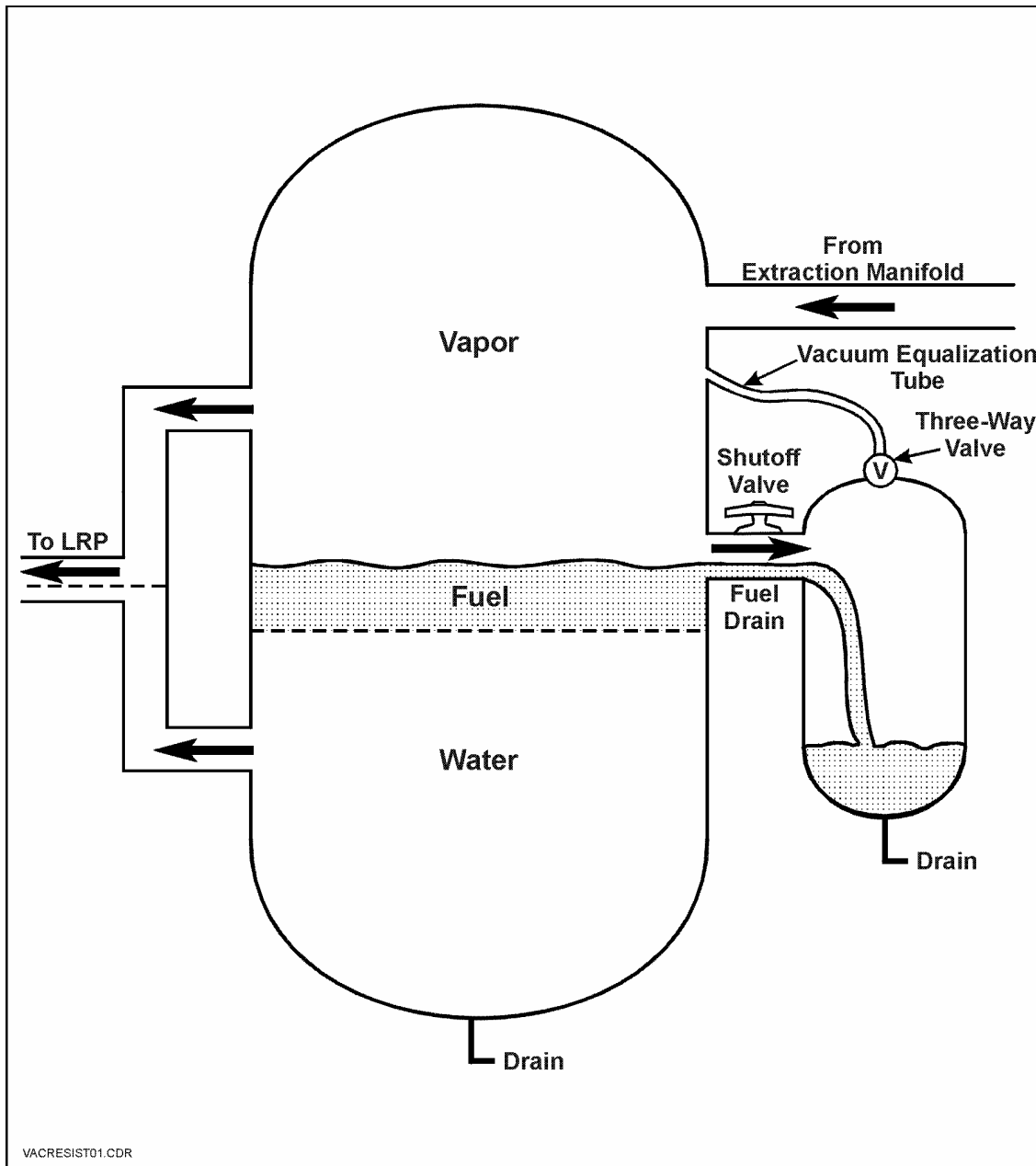

VACRESIST01.CDR

Figure 1. Schematic of a Typical Knockout Tank System

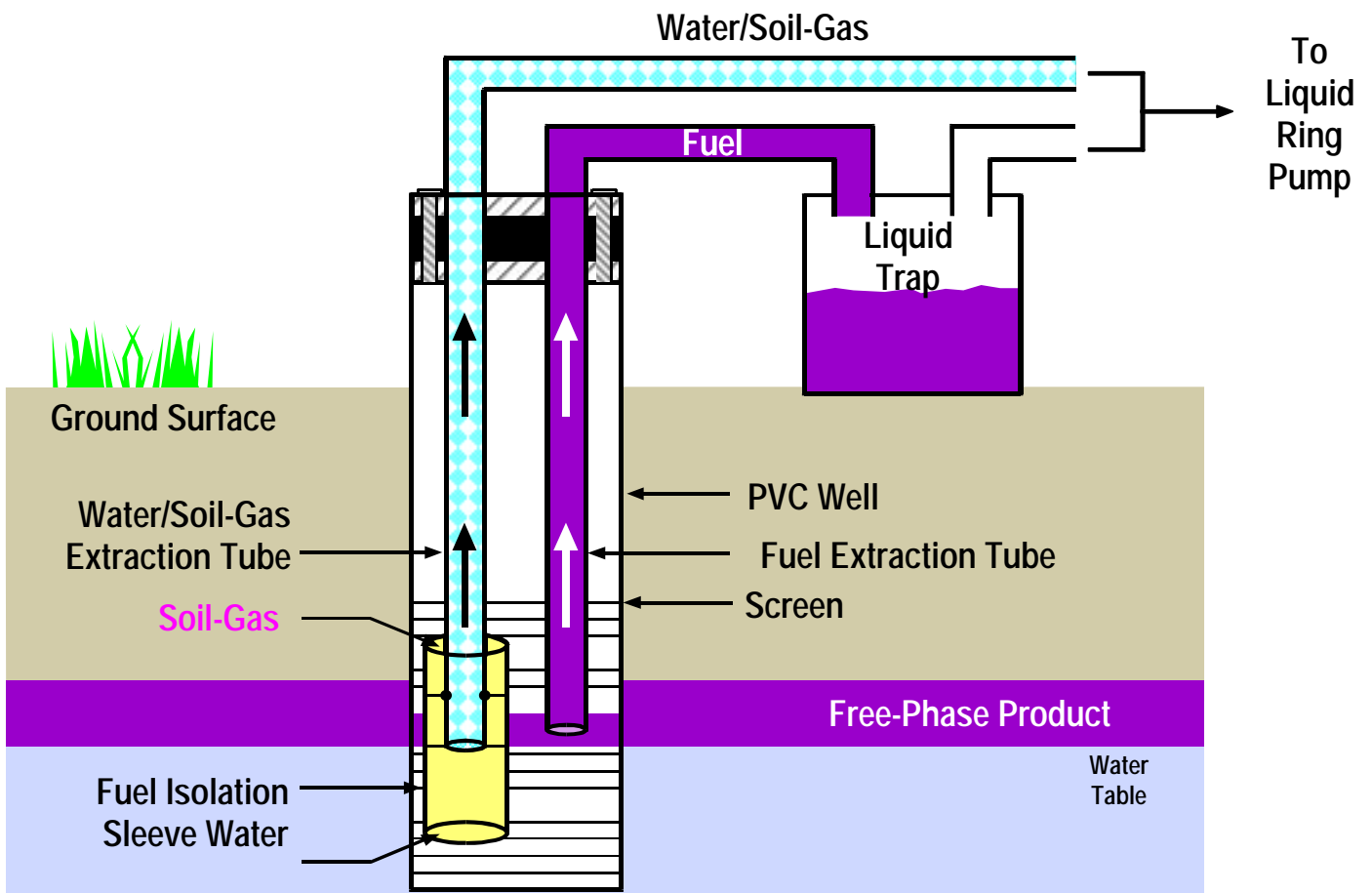

Figure 2. Dual Drop Tube Design (not to scale)



Figure 3. Dual Drop Tube Assembly

Section 3.0: DESIGN OF THE PREPUMP SEPARATION SYSTEMS

3.1 Design of the Knockout Tank

An engineering design of the knockout tank is provided in Figure 4. The center of the knockout tank begins with an air compressor (air receiver) tank. The size of the knockout tank is dependent on the fuel recovery rate expected at the site. During the ESTCP demonstrations, a 125-gallon tank was used with LNAPL recovery rates ranging from 1 to 120 gallons per day, and a 125-gallon tank likely would be adequately sized for most full-scale bioslurper systems. With a 125-gallon tank and the design described in this guide, the LNAPL storage capacity would be about 60 gallons. Typically, these tanks do not have receptacle fittings in the appropriate locations for a bioslurper knockout tank; therefore, the fittings need to be installed (welded) into the stock tanks. A certified machinist should perform all modifications to the tank.

The inlet to the knockout tank should be constructed by the addition of a 2 to 3-inch diameter coupling. This fitting should be installed approximately 12 inches from the top of the tank. On the inside of the tank, a tee fitting should be added and oriented with the openings in the vertical position. Sections of pipe are then added to the top and bottom of the fitting. The vertical pipe attached to the bottom of the fitting should be long enough to reach below the fluid level in the tank. The top vertical pipe should be long enough to avoid entrance of liquid from the tank (about 4-inch length). These fittings prevent disturbance of the fluid surface in the tank.

On the opposing side of the tank from the inlet, two ports should be installed at about 1/4 and 3/4 the length of the tank (15 and 55 inches from the top of the tank, respectively). These fittings should be 2 to 3 inches in diameter. A piping manifold should connect the two openings with a tee fitting, placed at approximately 27 inches below the top of the tank. When the knockout tank is fitted to the bioslurper system, the location of the tee should be placed higher than the inlet of the liquid ring pump.

Two one-inch-diameter half-couplings should be installed at the top and bottom of the tank. Ball valves should be attached to both of these openings. The top port allows the air to bleed into the tank during the draining of the fuel from the tank and the port at the bottom of the tank is used when the tank is drained and cleaned. The addition of a site glass on the side of the tank is useful

in determining the fluid levels in the tank and allows for the identification of the fluids captured in the tank. The user should determine the actual design and use of the sight glass.

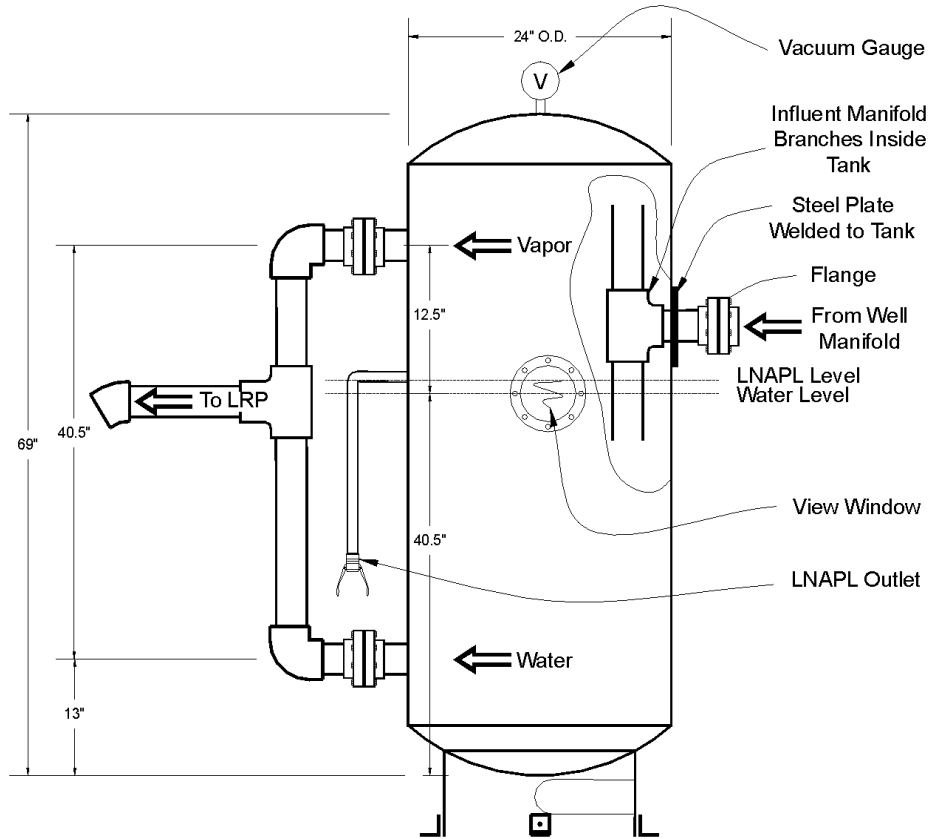

Figure 4. Engineering Specifics for the Knockout Tank

3.2 Design of the Dual Drop Tube

Figure 5 is a diagram of the dual drop tube assembly, showing the primary drop tube for removal of groundwater and soil gas and a smaller drop tube for LNAPL collection. The primary drop tube usually consists of a one-inch PVC pipe. The lower end of the primary drop tube is shielded with a larger diameter section of open-ended pipe that extends both above and below the end of the primary drop tube. This shield, which is usually a section of two-inch PVC pipe that can fit within the extraction well casing, is termed the “fuel isolation sleeve”. The recommended length for the fuel isolation sleeve is four feet, with approximately two feet extending both above and below the water table. However, there is no functional reason to limit the length of the fuel

isolation sleeve that extends above and below the liquid in the sealed extraction well. A shield that extends much less than two feet above the water table could be overtopped by a large accumulation of fuel. Although a sleeve that extended only a foot below the water table was effective at most sites during short-term field demonstrations, occasional influxes of fuel were experienced during a long-term field demonstration and when bioslurping LNAPL from a depth of 45 feet.

At the top of the well, a ball valve should be placed on the groundwater/soil gas drop tube to allow for regulation of vacuum in the drop tube. Also, a flexible section of hose should be placed between the extraction manifold and the drop tube to allow for adjustment of the depth of the drop tube in the well. The diameter of the extraction manifold is dependent on the number of wells attached to the bioslurper system, the groundwater-recovery rates and the fuel recovery rates.

A smaller diameter (usually ¼-inch-diameter) drop tube extends along the outside of the fuel isolation sleeve, with its lower end situated about a half-inch above the end of the primary drop tube. This smaller tube serves to remove LNAPL and any emulsion layer that collects at the water table near the well. The LNAPL extracted from the well is transported to a liquid trap situated before the liquid ring pump and under pump vacuum. The volume of this liquid trap is dependent on the LNAPL recovery rate expected at the site, and the frequency of the O&M visits to the site. In general, minimum storage capacity of the liquid trap should allow for daily visits to the site. Also, a larger diameter (e.g., half-inch-diameter) LNAPL extraction drop tube may be used if LNAPL is accumulating in the well.

Outside the well and just above the airtight well casing, ball valves should be attached to both the primary and fuel drop tubes to allow for adjustment of their liquid and vapor flow rates. Also, a section of clear tubing should be attached to both drop tubes above the well casing to allow for proper well depth adjustment by observing liquid and vapor flow rates through the clear sections.

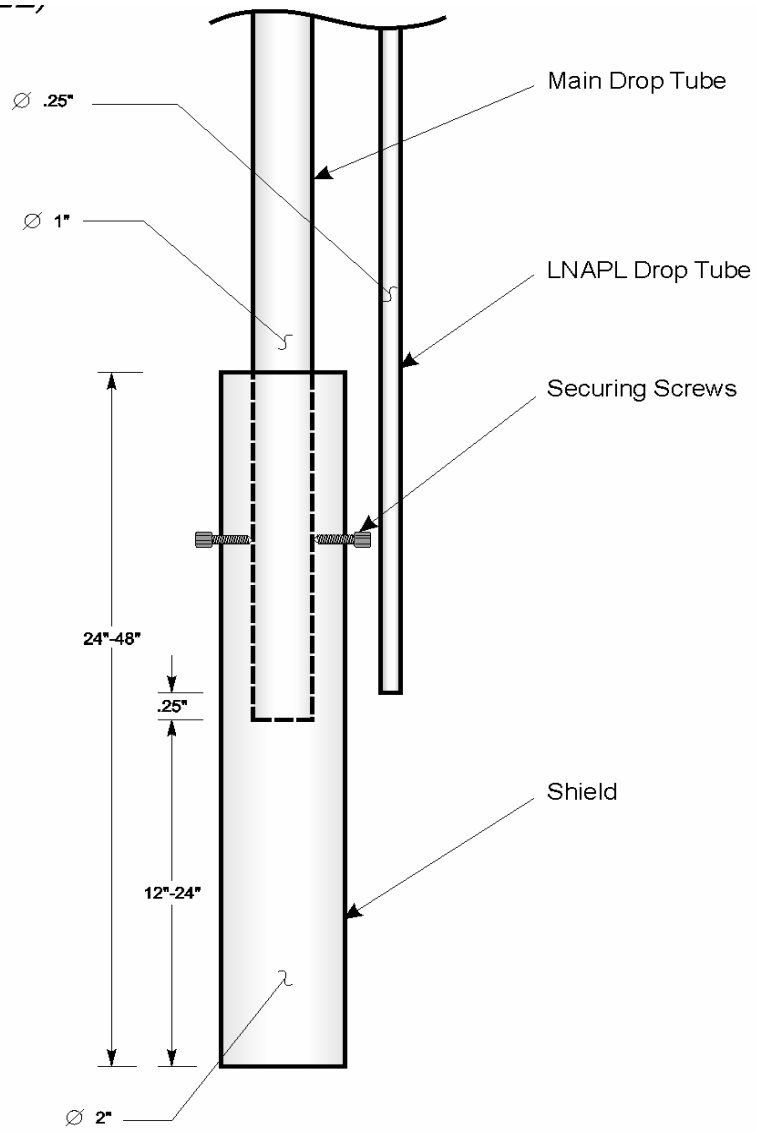

Figure 5. Engineering Design of the Dual Drop Tube System

Section 4.0: OPERATION AND MAINTENANCE OF PREPUMP SEPARATION SYSTEM

4.1 Operation and Maintenance of the Knockout Tank

Operation of the knockout tank is extremely simple. Once the knockout tank has been fabricated and placed in-line with the bioslurper system, it does not require any adjustments. Uniform water level is maintained in the tank by properly locating the tee fitting that connects the tank with the pump. If the knockout tank design does not allow for automatic drainage of fuel from the knockout tank to the fuel storage tank, manual drainage will have to be performed. The fuel may be removed from the tank anytime after the level of the fuel inside the tank has reached the fuel discharge port. Whether the knockout tank is drained manually or automatically, the knockout tank has to be at atmospheric pressure to drain the fuel from the tank. Therefore, a valve should be placed between the knockout tank and the pump to allow for isolation of the knockout tank. Also, the port on the top of the knockout tank should be opened to allow airflow into the tank during its drainage. The time required to manually drain the tank depends on the volume of the knockout tank and the LNAPL recovery rate. However, if the fuel is not drained out of the tank, it does not create a critical situation. The bioslurper system will continue to operate, but LNAPL will be carried through the system and into an oil-water separator after the pump (i.e., the bioslurper system will operate in the conventional configuration).

The knockout tank also requires very little maintenance. Periodically, the knockout tank should be shut down and completely drained. During operation, sediment will settle from the liquid stream inside the knockout tank. To prevent the accumulated sediment from blocking the lower ports of the knockout tank, the sediment should be removed on a regular basis. The frequency of this drainage is dependent on the quality of the water passing through the system.

The knockout tank, although providing inferior treatment of the extracted groundwater compared to the in-well separator, can serve as a backup to the in-well separation system and to dampen manifold line water surges that can damage the liquid ring pump. Therefore, simultaneous use of both pre-pump separators is recommended.

4.2 Operation and Maintenance of the Dual Drop Tube

The primary drop tube is passed through a sanitary seal at the top of the well and the end of the primary drop tube is placed at or near the LNAPL/water interface. At this depth, the groundwater extraction rate can be effectively handled and soil gas is simultaneously removed at a rate that maximizes fuel recovery. The depth of the bottom of the fuel isolation tube should also be determined since it should be located at least 6 inches above the bottom of the well casing to prevent sediment extraction or blockage. The smaller drop tube also should be passed through the sanitary seal at the top of the well. Most sanitary seals do not have an opening small enough to accommodate a ¼ inch tube; therefore, a thermocouple fitting likely will be required to place the fuel removal drop tube in the sanitary seal and maintain vacuum in the well. Initially, the end of the smaller diameter drop tube should be situated about a half-inch above the fuel/groundwater interface, while the fuel isolation sleeve would extend both above and below the LNAPL layer on the water table.

During the operation of the dual drop tube system, both the primary and fuel drop tubes should be operated at maximum vacuum levels. In most cases, the vacuum levels will not need adjustment, but observations of the fluid flow out of the well should be performed to see if adjustments need to be made. Also, the depths of the drop tubes may need to be adjusted to extract fluids from both drop tubes simultaneously.

Two methods of dual drop tube operation were used during the ESTCP demonstrations, and were dependent on the fuel recovery rate. When fuel recovery rates were relatively low (<3 gpd/well) the bioslurper system was operated with the primary drop tube set at the maximum vacuum level while the vacuum to the fuel drop tube was turned off. Operation in this mode allows the fuel to accumulate within the well. Periodically, the vacuum to the fuel drop tube is turned on and all of the fuel that has accumulated in the well is removed. Typically, fuel was removed on a daily basis when fuel recovery rates were <3 gpd/well. The frequency of fuel removal is dependent on fuel recovery rate, and the fuel should not accumulate to a thickness where it pushes under or flows over the isolation shield. When fuel recovery rates were greater than 3 gpd/well, the vacuum to the fuel drop tube was set at a maximum level and remained on continuously. In this

operational mode, fuel is constantly being removed from the well, preventing excessive fuel accumulation. Constant operation may require more frequent adjustments of both drop tubes to maintain consistent flow from the well, especially at sites with short-term water table fluctuations greater than one foot. During the ESTCP demonstrations, the dual drop tube system was tested at sites with tidal fluctuations of <1 foot. Performance of the dual drop tube system was not affected by fluctuations of this magnitude, but it is uncertain how larger fluctuations affect the system.

4.3 Troubleshooting of the Prepump Separation Systems

In general, operation of the prepump separation systems is simple and trouble free. The knockout tank contains no moving parts and mechanical adjustment of the system is minimal. The only problem that was encountered during demonstration of the technology was the blockage of the lower port and drain with sediment. Frequent removal of the sediment eliminates problems associated with sediment buildup.

The dual drop tube system also is relatively simple and trouble free. One error that can occur with the operation of the dual drop tube is placement of the fuel recovery drop tube inside the isolation shield of the primary drop tube. This error results in limited recovery of fuel with the fuel recovery drop tube and the buildup of fuel inside the well.

During operation in the dual drop tube configuration, some adjustment of both drop tubes is generally required. Also, the vacuum in the well and the extraction manifold should be monitored on a regular basis. The vacuum levels at each of these points are dependent on the overall design of the system (i.e., the extraction pump size, number of wells, etc.). However, the vacuum in the manifold and well should be as high a possible. If vacuum is measured in the extraction manifold, little vacuum is measured in the well, and fluids are not being extracted from the well, the vacuum may not be great enough to lift fluid to the surface. In this situation, provided that the well tests airtight, some air should be introduced into the well through an

adjustable vent in the well seal or by slightly loosening the well seal to enhance the lifting capabilities of the system.

Section 5.0: COST ASSESSMENT

A long-term demonstration at NAS Fallon was conducted primarily to investigate the cost-effectiveness of the pre-pump separation operation compared to operation in the conventional configuration (single drop tube and no pre-pump knockout tank). During the long-term demonstration, the system was operated in a multiple well (five-well) configuration to simulate full-scale design and potential operational problems. Also, the test duration was approximately 3.5 months, so more accurate costs for “long-term” operation could be assessed. All of the tests were designed to provide a side-by-side comparison of the performance and operational requirements in each configuration. For example, operation and maintenance labor requirements were recorded for each of the configurations to determine if one of the configurations was more cost-effective than the others evaluated. Therefore, the demonstration was conducted to compare the bioslurper system performance and costs with and without each (or both) of the prepump separation systems evaluated.

The data presented in this section will compare the cost performance of bioslurping in the conventional configuration with the in-well separation configuration. Although the knockout tank was tested alone during the long-term demonstration, the cost and performance data did not indicate that it performed adequately. Therefore, costs for the knockout tank operation alone were not calculated. The cost assessment of the conventional bioslurper system includes two scenarios: (1) with manual removal and disposal of the floating solids, and (2) treatment of the aqueous discharge stream with a dissolved air floatation (DAF) system. Treatment costs in the conventional configuration are estimated because the recovered discharge water and LNAPL at NAS Fallon did not produce a significant amount of floating solids that needed to be removed. Additionally, the regulated aqueous discharge limits were relatively high, so the aqueous discharge stream did not require treatment past the OWS.

The estimated full-scale costs for performing in-well “dual drop tube” separation at a generic site is provided in Table 1. This generic site contains an LNAPL plume that covers an area of two acres, with the water table at a 15-ft depth. The radius of influence from each extraction well is estimated to be 40 feet, thus requiring the installation of 50 extraction wells. This generic site is based on an average condition determined from performing bioslurping at 40 LNAPL-contaminated DoD sites. The in-well “dual drop tube” separation assembly was estimated to cost \$17,000 to install in all 50 extraction wells. The other operational costs are universal to all bioslurper systems. Costs for full-scale conventional bioslurping, with manual removal of floating solids, are given in Table 2. Costs for full-scale conventional bioslurping, with DAF for treating floating solids, are presented in Table 3.

Comparison of the cost data in Tables 1 to 3 demonstrates the cost-effectiveness of the in-well “dual drop tube” bioslurper system, compared to conventional (single drop tube) operation with manual or DAF treatment of the OWS. Over the expected duration of the LNAPL recovery effort (2 years), the in-well separation system saves about \$306K and \$336K, relative to conventional bioslurping with manual and DAF post-pump treatment, respectively. The remediation time when employing pre-pump separation should be shorter than for conventional bioslurping because the LNAPL removal rate is equivalent while system maintenance time should be less, such as to manually clean the OWS, repair the DAF system, or more frequently repair the pump.

Table 1. Estimated Full-Scale Implementation Costs for Conducting In-Well Separation Bioslurping^(a)

Cost Category	Subcategory	Costs (\$)
<i>FIXED COSTS</i>		
1. CAPITAL COSTS	Mobilization/demobilization	\$15,000
	Demonstration Plan	\$10,000
	Materials	
	- Dual-Drop Tube Assembly	\$17,000
	- Manifold	\$8,000
	- Gauges	\$2,300
	Bioslurper Cost	
	- 20-hp Liquid-ring pump	\$12,200
	- Oil/water separator	\$11,500
	- Surge Tank	\$2,000
	- Fuel Trap	\$800
- Sump Pumps	\$500	
- Hardware	\$7,500	
- Labor	\$10,000	
Installation		
- Drilling	\$41,000	
- Electrical	\$5,000	
- Trenching	\$1,000	
		Subtotal \$143,800
<i>VARIABLE COSTS</i>		
2. OPERATION AND MAINTENANCE	Labor	
	- Technician ^(b)	\$74,128
	- Engineer ^(c)	\$26,112
	Materials and Consumables	
	- Carbon treatment of effluent water	\$40,000
	- Other	\$5,000
	Analysis	
- Effluent water sampling ^(d)	\$10,000	
- Off-gas sampling ^(e)	\$10,000	
		Subtotal \$165,240
TOTAL COSTS		
TOTAL TECHNOLOGY COST: \$309,040		
Quantity Treated: 2 acre		
Unit Cost (\$):154,520/acre		

- (a) Based on a 2-acre area with 50 wells (4" diameter at 15 ft depth) operating for 2 years.
- (b) Technician time for full-time for the first month, then 2 days per week for rest of project.
- (c) Engineer time for 40 hours for first month, then 16 hours per month for rest of project.
- (d) Effluent water will be tested weekly for first month, then monthly for rest of project.
- (e) Air sampling will be conducted weekly for first month, then monthly for rest of project.

Table 2. Estimated Full-Scale Implementation Costs for Conducting Bioslurping with Manual Removal of Floating Solids ^(a)

Cost Category	Subcategory	Costs (\$)
<i>FIXED COSTS</i>		
1. CAPITAL COSTS	Mobilization/demobilization	\$15,000
	Demonstration Plan	\$10,000
	Materials	
	- Well Assembly	\$7,000
	- Manifold	\$8,000
	- Gauges	\$2,300
	Bioslurper Cost	
	- 20-hp Liquid-ring pump	\$12,200
	- Oil/water separator	\$11,500
	- Surge Tank	\$2,000
	- Fuel Trap	\$800
- Sump Pumps	\$500	
- Hardware	\$7,500	
- Labor	\$10,000	
Installation		
- Drilling	\$41,000	
- Electrical	\$5,000	
- Trenching	\$1,000	
		Subtotal \$133,800
<i>VARIABLE COSTS</i>		
2. OPERATION AND MAINTENANCE	Labor	
	- Technician ^(b)	\$170,560
	- Engineer ^(c)	\$26,112
	Materials and Consumables	
	- Carbon treatment of effluent water	\$240,000
	- Other	\$5,000
	Sludge and Waste Disposal	\$20,000
	Analysis	
	- Effluent water sampling ^(d)	\$10,000
	- Off-gas sampling ^(e)	\$10,000
		Subtotal \$481,672
TOTAL COSTS		
		TOTAL TECHNOLOGY COST: \$615,472
		Quantity Treated: 2 acre
		Unit Cost (\$):307,736/acre

(a) Based on a 2-acre area with 50 wells (4" diameter at 15 ft depth) operating for 2 years.

(b) Technician time for full-time for the entire project.

(c) Engineer time for 40 hours for first month, then 16 hours per month for rest of project.

(d) Effluent water will be tested weekly for first month, then monthly for rest of project.

(e) Air sampling will be conducted weekly for first month, then monthly for rest of project.

Table 3. Estimated Full-Scale Implementation Costs for Conducting Bioslurping with DAF Unit for Postpump Treatment^(a)

Cost Category	Subcategory	Costs (\$)
<i>FIXED COSTS</i>		
1. CAPITAL COSTS	Mobilization/demobilization	\$15,000
	Demonstration Plan	\$10,000
	Materials	
	- Well Assembly	\$7,000
	- Manifold	\$8,000
	- Gauges	\$2,300
	- DAF Unit	\$77,000
	Bioslurper Cost	
	- 20-hp Liquid-ring pump	\$12,200
	- Oil/water separator	\$11,500
	- Surge Tank	\$2,000
- Fuel Trap	\$800	
- Sump Pumps	\$500	
- Hardware	\$7,500	
- Labor	\$10,000	
Installation		
- Drilling	\$41,000	
- Electrical	\$5,000	
- Trenching	\$1,000	
		Subtotal \$210,800
<i>VARIABLE COSTS</i>		
2. OPERATION AND MAINTENANCE	Labor	
	- Technician ^(b)	\$170,560
	- Engineer ^(c)	\$26,112
	Materials and Consumables	
	- Carbon treatment of effluent water	\$40,000
	- Chemicals	\$153,000
	- Other	\$5,000
	Sludge and Waste Disposal	\$20,000
	Analysis	
	- Effluent water sampling ^(d)	\$10,000
	- Off-gas sampling ^(e)	\$10,000
		Subtotal \$434,672
TOTAL COSTS		
		TOTAL TECHNOLOGY COST: \$645,472
		Quantity Treated: 2 acre
		Unit Cost (\$):322,736/acre

(a) Based on a 2-acre area with 50 wells (4" diameter at 15 ft depth) operating for 2 years.

(b) Technician time for full-time for the entire project.

(c) Engineer time for 40 hours for first month, then 16 hours per month for rest of project.

(d) Effluent water will be tested weekly for first month, then monthly for rest of project.

(e) Air sampling will be conducted weekly for first month, then monthly for rest of project.

Section 6.0: REFERENCES

- Hoeppel, R., M.C. Place, C.T. Coonfare, S.H. Rosansky. 1998. *Application Guide for Bioslurping, Vols. I and II*. Tech. Memo. TM-2300-ENV and TM-2301-ENV. Naval Facilities Engineering Service Center, Port Hueneme, CA
- Place, M., C.T. Coonfare, A.S.C. Chen, R.E. Hoeppel, S.H. Rosinsky. 2001. *Principles and Practices of Bioslurping*. Battelle Press, Columbus, OH.
- Wickramanayake, G.B., J.A. Kittel, M.C. Place, R. Hoeppel, A. Walker, E. Drescher, J.T. Gibbs. 1996. *Best Practices Manual for Bioslurping*. Tech. Memo. TM-2191-ENV. Naval Facilities Engineering Service Center, Port Hueneme, CA.